

TRAKMIX

MOBILE CONTINUOUS MIXING PLANT



TRAKMIX 250

The Rapid Trakmix 250 is a track-mounted mobile continuous concrete mixing plant/ pugmill available in the market. The Trakmix is totally mobile, self-contained, fully weighed and outputs high volumes of up to 250 TPH and delivers the most accurate, reliable and powerful mobile continuous mixing technology to a wide range of contractors worldwide.

Rapid International's Trakmix 250 has been designed to be totally mobile and completely self-contained with its own power source. A Hydraulically operated track system enables the plant to self-position and self-erect in minutes.

The Trakmix 250 is a continuous weighing and mixing system, mixing up to 250 tonnes per hour. Feed rates are fully adjustable for the aggregate, cement and water systems.

The robust design with optional features such as Admix Systems or belt scale weigher to name a few, make the Trakmix 250 the most versatile mobile pugmill on the market today.



The Trakmix 250 is ideal for applications where all types of binders or neutralising powders are required in the mixing process, including road construction, road paving, ground



works/civil engineering, environmental stabilisation projects, aggregate recycling and many more.

Tier 3, 4 or 5 Diesel powered by world renowned engine brands, combined with powerful hydraulics and auto feeder speed control guarantee the machine is always functioning at its optimum level.

The plant is controlled by an Allen Bradley Micrologix Processor to control all of the plant functions for automatic control with manual control backup via the HMI touchscreen interface. Software features include the option to store up to 50 recipes detailing specific mixtures, stock control, batch recording printer, and plant alarms.



TECHNICAL DATA

TRANSPORT DIMENSIONS	AGGREGATE WEIGH BELT FEEDER	GENSET
Length: 13.82m (45' 34")	Supported on compression loadcells - pivot arrangement	153KVA 3 Phase, 480/277 volts, 60 Hz, 1800 RPM
Width: 2.53m (8' 3")	1400mm (4.6ft) wide 3 Ply Plain Belt	152kVA 3 Phase, 400/230 volts, 50Hz, 1500RPM
Height: 4.04m (13' 28")	Belt Length: 860mm (2'82") c/c	Tier 3/4/5 & LRC Volvo or Scania power unit
Weight: 27000 kg (27 Tonnes) (59524.81 lbs)	OUT-LOADING CONVEYOR	8 hour capacity baseframe fuel tank
WORKING DIMENSIONS	800mm (31.5") 3 Ply Heavy Duty Vulcanised belt	Electric starting system and battery charging system
Length: 17.28m (56' 7")	Motorised drum with rubber lagging	Automatic engine shutdown protection equipment
Width: 2.53m (8' 3")	Polyurethane blade precleaner scraper	Heavy duty steel skid type base frame
Height: 4.68m (15' 35")	WATER SYSTEM	Anti-vibration mounting pads
AGGREGATE HOPPER	Tank Capacity: 600 litre (158.5 US gal)	Excellent service access
Capacity: 7.5m ³ (9.8 yds ³)	Fitted with ball valve & galvanised pipework	PLANT CONTROL SYSTEM
Loading Width: 4100mm (4.1m) (13.45 ft)	Controlled via a level probe and piston shutoff valve	Allen Bradley Micrologix Processor
Removable Division Plate for twin material loading	One positive displacement pumps to supply water spray bars	Fully automatic control with manual override
Lining: Low friction 12mm (1/2") Polyethylene	Calibration point for accurate water weighing included	15" Touch screen HMI operator interface
Adjustable outlet end	CEMENT / BINDER WEIGH VESSELS	Backup laptop PC for remote operation
BELT FEEDER	Screw conveyors mounted under the weigher	Storage of up to 50 mixing recipes
Heavy duty geared motor drive	Outlet rotary valve controls feed into twin outlet screw conveyor	Stock control
Automatic variable speed control	Automatic diverter valve to divert material into hopper	Built in Batch record printer
Adjustable rubber skirting	PNEUMATIC SYSTEM	Plant alarms
Heavy duty support rollers	Compressor with 200L Capacity Receiver tank	Remote access via Wifi & 3G Network connection
1200mm (4ft) wide 3 Ply Plain Belt	Max Working Pressure: 12 BAR (Safety Valve Setting)	Starter Panel housing all drive motor starters
TWIN SHAFT CONTINUOUS MIXER	Solenoid Spool Valves fitted to control Gob hopper doors	Weighing monitor via compression loadcells
Drive: 55kW (75HP) Electric Motor	Regulator with pressure gauge to adjust the pressure	Litre counter to measure the flow rate of water into the mixer
Reduction gearbox with twin gears	Max / Min Working Temperature: +110°C / -10°C	CHASSIS
Chill cast mixing tools & paddles	HYDRAULIC SYSTEM	2No Tracks: 3.3m (10.82ft) wide x 0.74m (2.43ft) high
Total access to mixer via top and side hatches	Hydraulic Powerpack	Electro-hydraulic powerpack to operate the track system
Dual spraybars for water dosing.	Lever Operated Control Valves	Walkways are provided on top of the chassis of the machine for maintenance access
Floor conveyor for mixer cleanout	Double Acting Hydraulic Cylinders	Fold-out ladder on both sides for ease of access

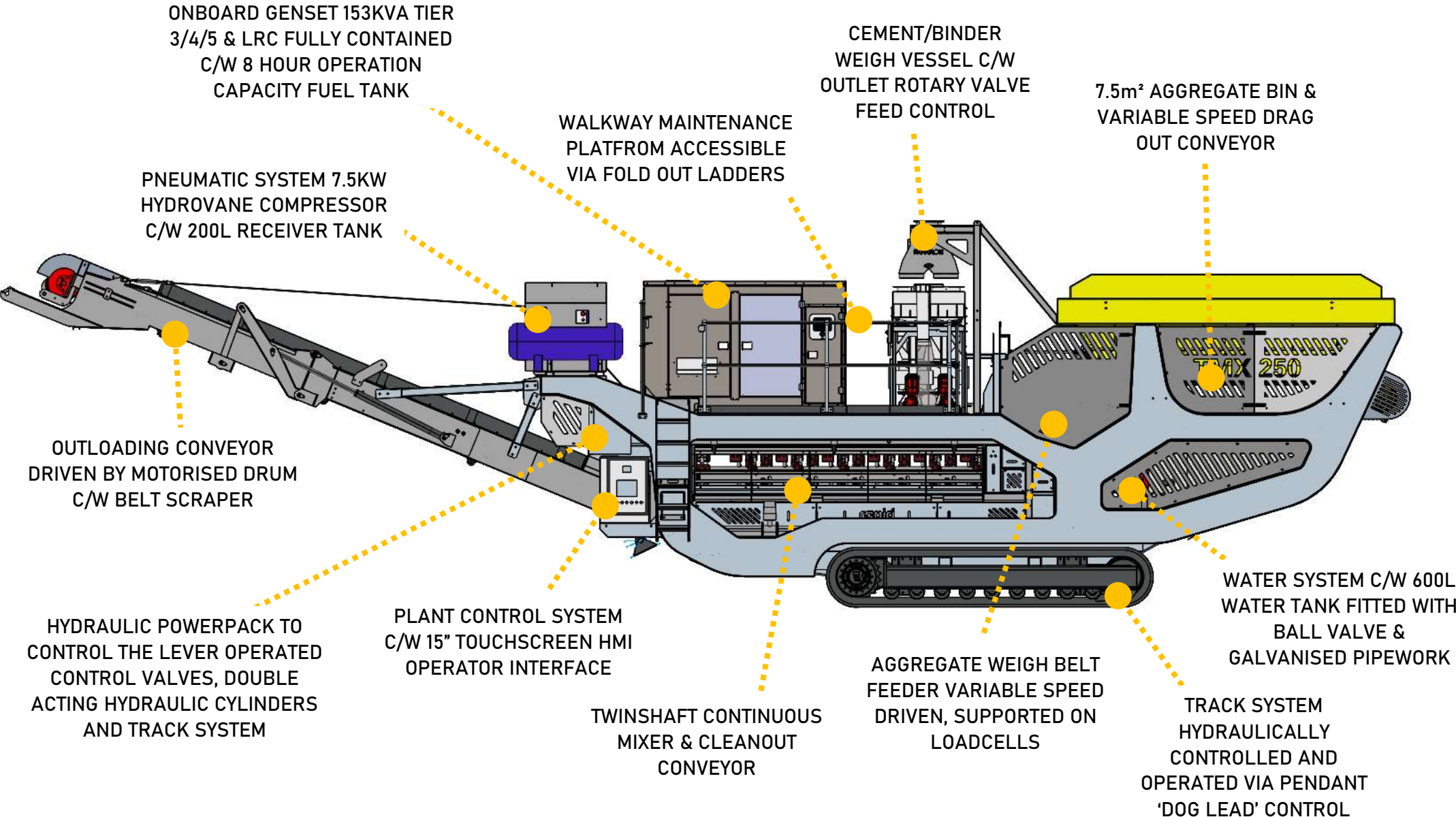

OPTIONS

ADMIX SYSTEM

Self-contained units

Outputs available: 12 LPM, 28 LPM, 50 LPM (Litres per Minute)

Up to 4 Admix systems can be installed with separate outputs

AGGREGATE BINS OPTIONS

Option to have no aggregate bin division plate included on plant

Optional Hydronix Moisture Probe to the aggregate storage bin

Optional installation of a Vibrator bin cleaning system

Optional installation of a Single or Twin Aggregate Agitator to the Aggregate Bin area.

STATIC VIBRATING / HYDRAULIC GRID FOR HOPPER

Grid fitted to avoid oversized materials from entering the hopper

AUXILLARY SILO

Allows further application options

Preferred options are horizontal, however vertical silos are available

Available in multiple sizes

AUXILLARY SILO 'SOFTWARE READY'

Option to have plant's software and hardware setup in preparation for any future decision to add an Auxiliary Silo

Power & Communications outlet connected to the Auxiliary Silo from the Trakmix plant.

POWER CHANGE-OVER OPTION

Option to switch plant power source from Genset to direct mains power supply and vice-versa

The installation of a Changeover Switch provides Rapidmix with 'Power Change-over' capabilities

GOB HOPPER ATTACHMENT

Option to have a Gob Hopper attachment added to the Outloading Conveyor discharge end

Gob Hopper gives the option to 'hold' material before being dispensed at a discharge rate selected by the operator

CUSTOMISED PLANT

Customer colours can be used if specified

Additional Decals of the company brand & business info can be included

SOFTWARE UNITS DISPLAY

Rapid can offer to display all the units and figures that appear on the control panel in either Imperial units (ft or lbs) or Metric units (m or kgs)

Specification subject to change without notice

CONTACT US:

Rapid International Ltd.
96 Mullavilly Road
Tandragee
Craigavon
Northern Ireland
BT62 2LX

Tel: (+44) 028 3884 0671
Fax: 028 3884 0880

Dealer Stamp:

July 2025. The material in this document is for information only and is subject to change without notice. Rapid International assumes no liability resulting from errors or omissions in this document, or from the use of the information contained herein. Due to continual product development, we reserve the right to change specifications without notice. Any product performance figures given in this brochure are for guidance purposes only. This information does not constitute an expressed or implied warranty or guarantee, but shows text examples provided. Photographs are for illustrative purposes only. Some or all of the machines in the illustrations may be fitted with optional extras.

INTENTIONALLY BLANK

CHASSIS

CHASSIS:

Fully welded profiled plate sides with brackets fitted for attaching bin, conveyors, mixer, and all ancillary items which make up the plant.

RUNNING GEAR:

Tracks operated by hydraulic motors. A pendant control is fitted to operate the track system.

ACCESS:

Walkways are provided on top of the chassis of the machine for maintenance access. Fold out ladders for access.

HYDRAULIC SYSTEM:

Electro-hydraulic powerpack to operate the track system and the hydraulic rams for conveyor folding.

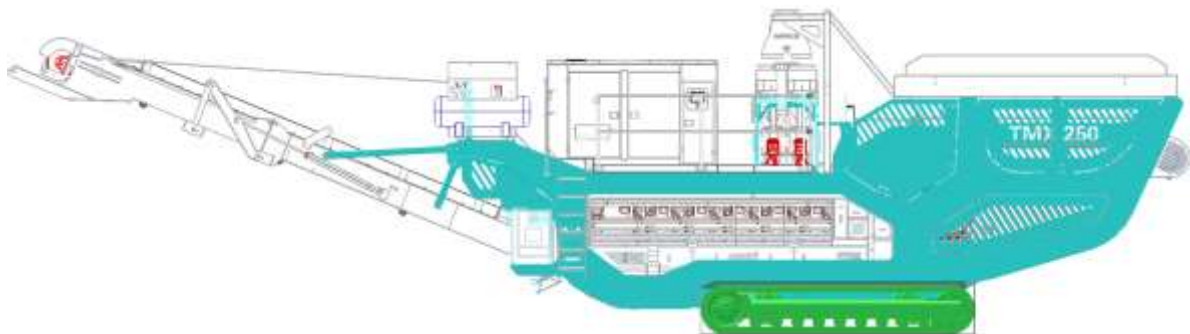
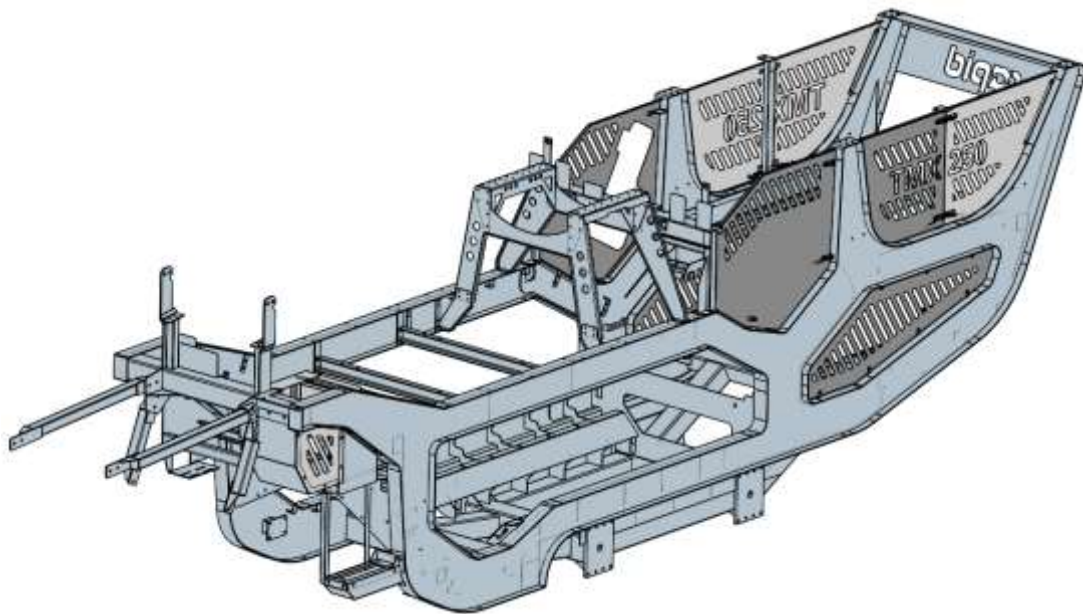

AGGREGATE HOPPER

AGGREGATE HOPPER:

- CAPACITY:** 7.5 m³ (9.8 yds³).
- LOADING WIDTH:** 1400 mm.
The hopper can be loaded from either side of the machine.
- CONSTRUCTION:** S275 plate with stiffening ribs. Steep sides for difficult materials. (end slopes of 60 degrees).
- REMOVEABLE DIVISION PLATE:** The hopper has a removable division plate, allowing two materials to be used.
- LINING:** To aid the discharge of the materials the hopper surfaces are fitted the low friction high molecular polyethylene lining material (1/2" (12mm) thickness).
- ADJUSTABLE GATES:** The outlet end of the hopper is fitted with adjustable level gates to enable the material height on the conveyor belt to be varied. These are adjusted manually.

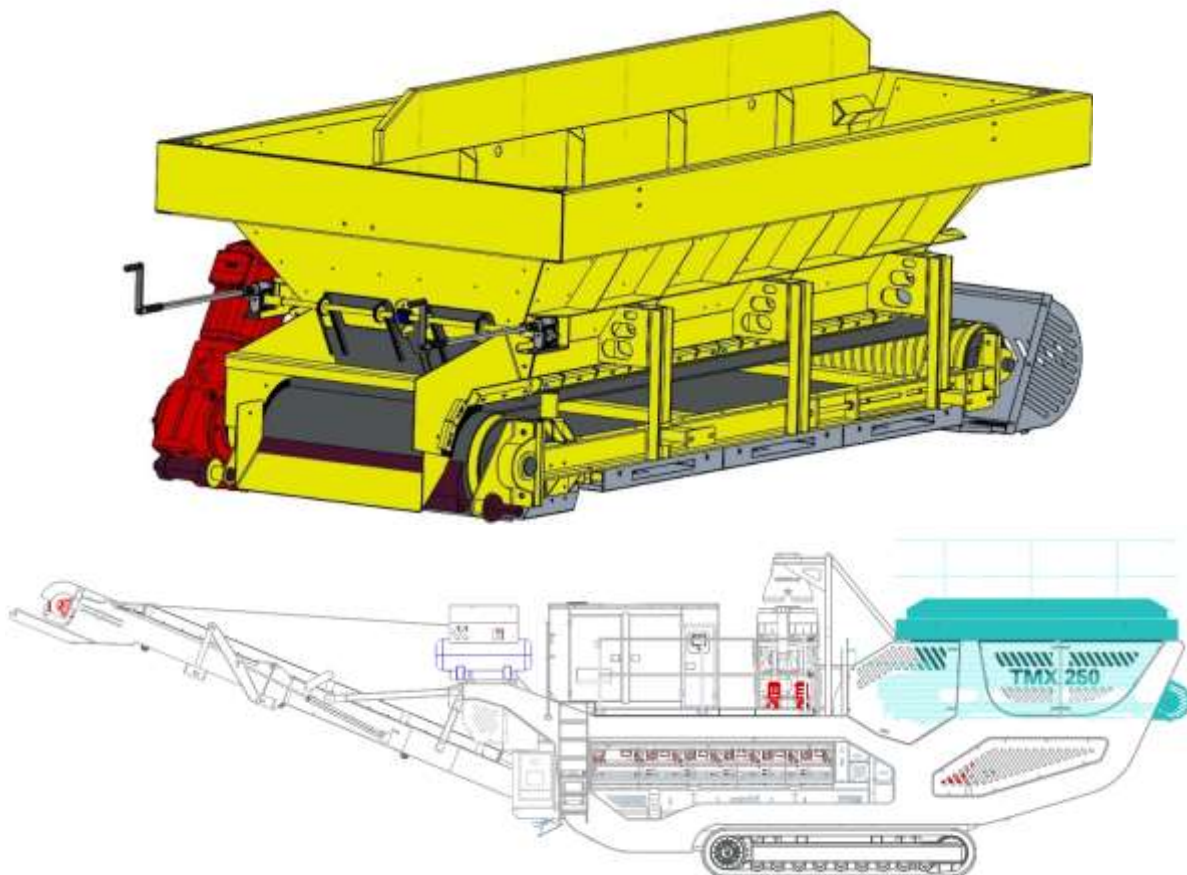

VARIABLE SPEED BELT FEEDER:

A Conveyor belt feeder is fitted on the bottom of the hopper to provide feed from the hopper to the mixer. The conveyor is fitted with a heavy duty geared motor drive with automatic variable speed control and is fitted with adjustable rubber skirts and additional heavy duty support rollers.

The belt width is 1200mm (4') and a heavy duty 3 ply belt is fitted.

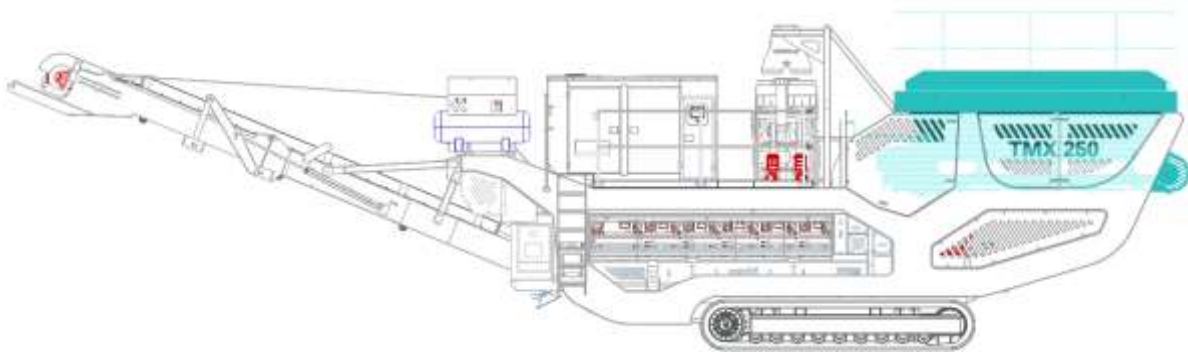
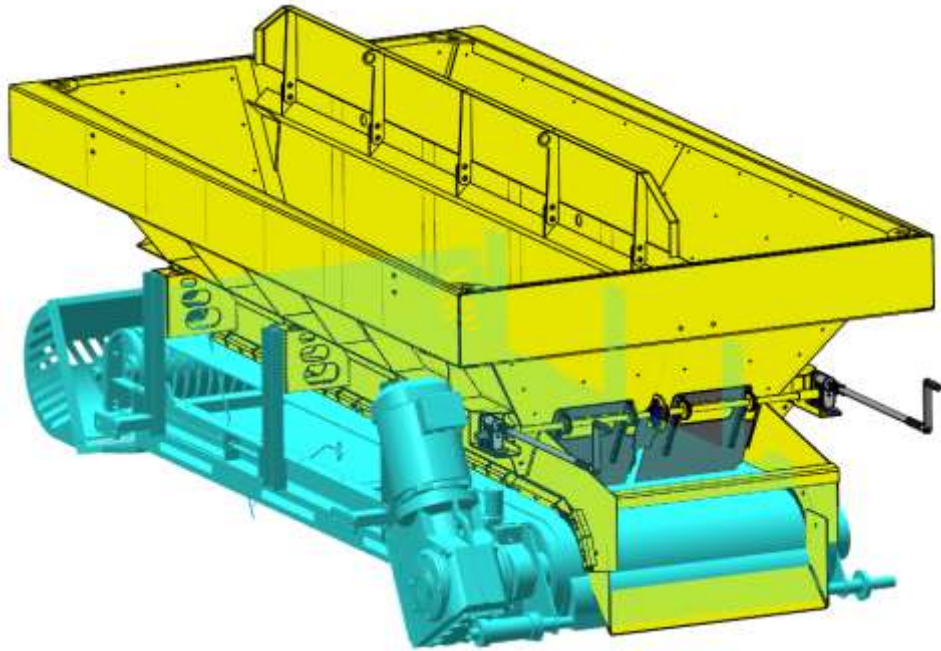

AGGREGATE WEIGHED FEEDER:

A Conveyor belt weighed feeder is fitted below the bottom of the main aggregate conveyor, supported on loadcells to provide feed from the hopper to the mixer with weighing capabilities. The conveyor is fitted with a motorised drum with automatic variable speed control and is fitted with adjustable rubber skirts and additional heavy duty support rollers.

The belt width is 1400mm and a heavy duty 3 ply belt is fitted

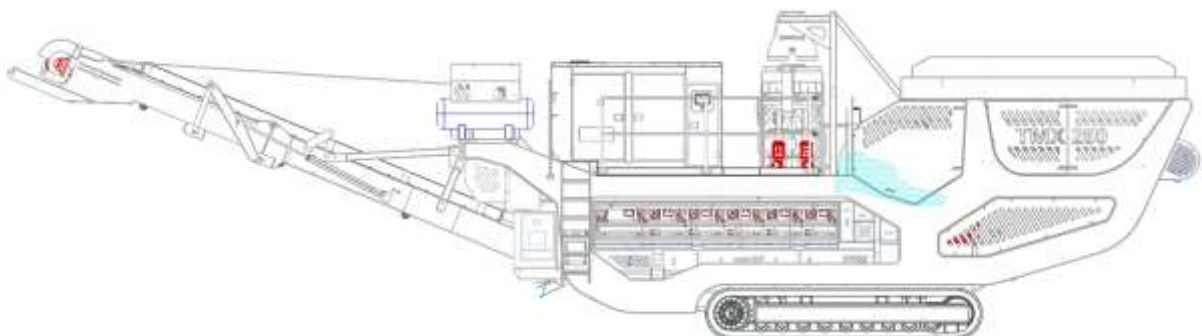
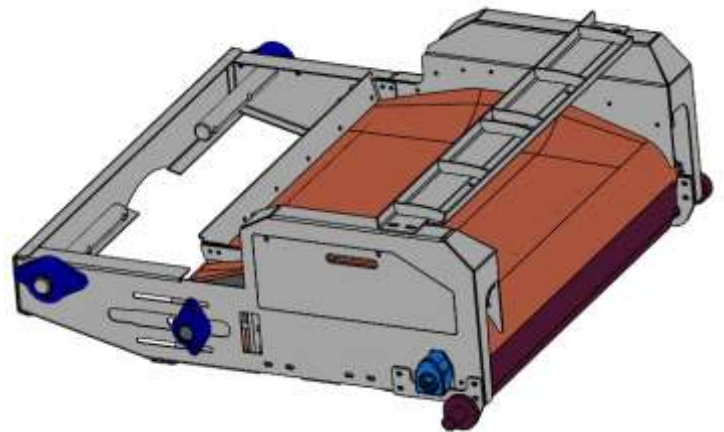

PUGMILL MIXER

TWIN SHAFT CONTINUOUS MIXER:

- MIXING ACTION:** The twin shafts mix the material, whilst moving the material toward the end of the mixer.
- PADDLES:** The twin horizontal mixing shafts are fitted with chill cast steel paddles, which are intermeshed in a specially phased relationship to optimise mixing action, whilst maximising throughput.
- CLEANING & MAINTENANCE ACCESS:** Special attention has been paid to give the user maximum access for maintenance and cleaning operations. The top of the mixer is fitted with hinged access covers, which when opened give access to all of the mixing chamber. Both sides of the mixing chamber hinge down, to give access, the sides are lowered by hydraulic cylinders.
- DRIVE:** The shafts are driven by a 55 kW (75 HP) electric motor through a reduction gearbox with twin gears to synchronise the shafts.
- MIXING CHAMBER:** The mixing chamber is formed by fabricated sloped sides with a troughed conveyor under the mixer forming the bottom of the mixer.
- WATER ADDITION:** Water spray bars fitted into the top of the mixer allow the water to be added to the material as it progresses along the mixer.

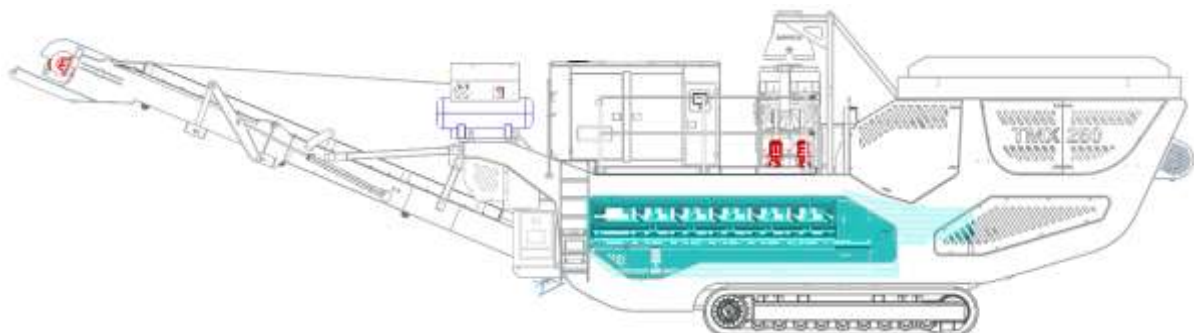

CLEAN-OUT CONVEYOR UNDER MIXER:

Mounted on the bottom of the mixer, forming the bottom of the mixing chamber, this conveyor allows the bottom of the mixer to be easily cleaned out, when production is finished. This conveyor is used for clean out purposes only. The mixer should be lined with a bed of material every morning before production starts. The conveyor is fitted with a low speed geared motor drive.

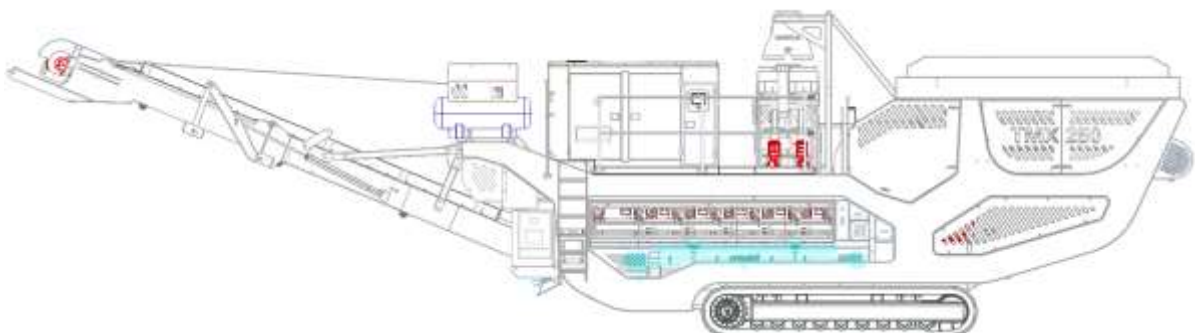
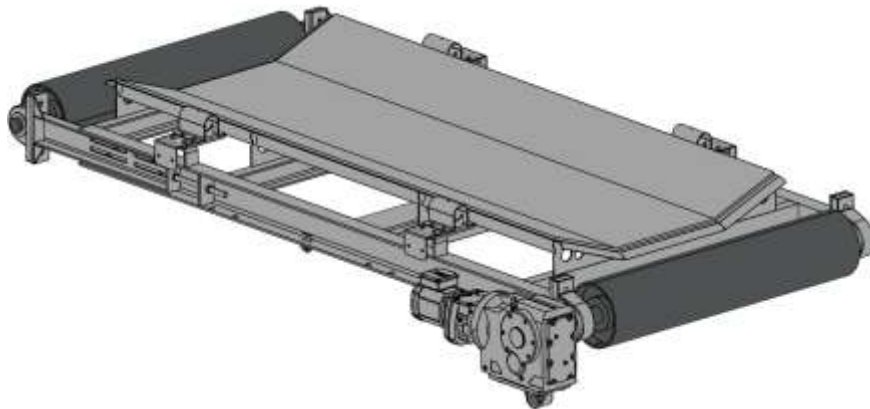

OUTLOADING CONVEYOR

OUT-LOADING CONVEYOR:

Transporting the mixed material from the twinshaft mixer to the truck. The conveyor is designed to handle the maximum feedrate from the mixer.

- CONSTRUCTION:** S275 folded plate construction with mounting brackets for rollers and pivoting mechanism. The head section of the conveyor folds for transportation.
- BELT:** 800mm width.
3 ply belt with heavy duty top cover and vulcanised joint.
- DRIVE:** Motorised drum with rubber lagging.
- BELT SCRAPER:** Polyurethane blade pre-cleaner scraper mounted on the face of the head drum.
- BELT SCALE WEIGHER:** To continuously measure and report flow rates and totalized amounts of materials being transported on the Out-loading Conveyor belt. The weight of the material transported is determined by weighing the belt load and measuring the belt speed.

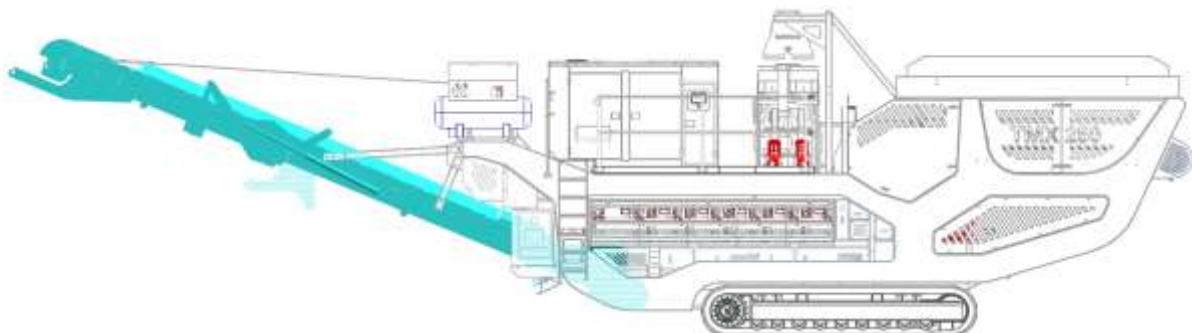

WATER SYSTEM

WATER SYSTEM:

WATER TANK:

A 600 litre tank is fitted complete with galvanised steel pipework. The water level is controlled via a level probe and piston shutoff valve.

PUMPS:

One positive displacement pump is fitted to supply 2No water spray bars within the mixer.

SPRAY BARS:

Each Mixer spray bar has a ball valve to allow addition of water early in the mix, later in the mix or both together. A calibration point for accurate water weighing is also included.

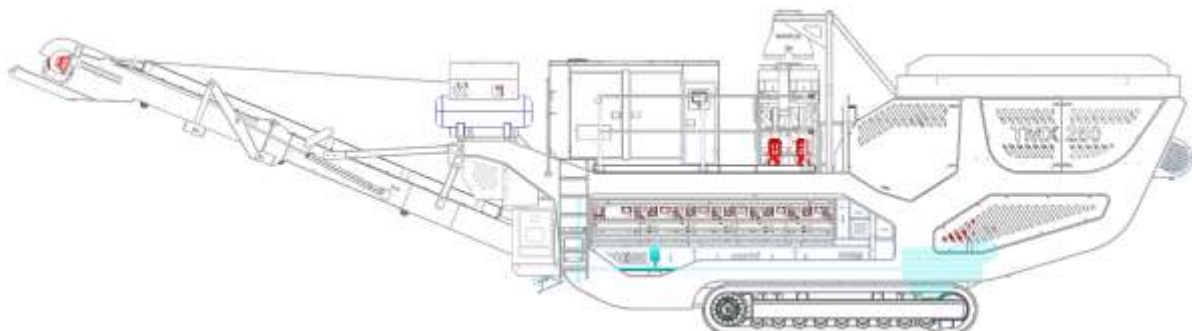
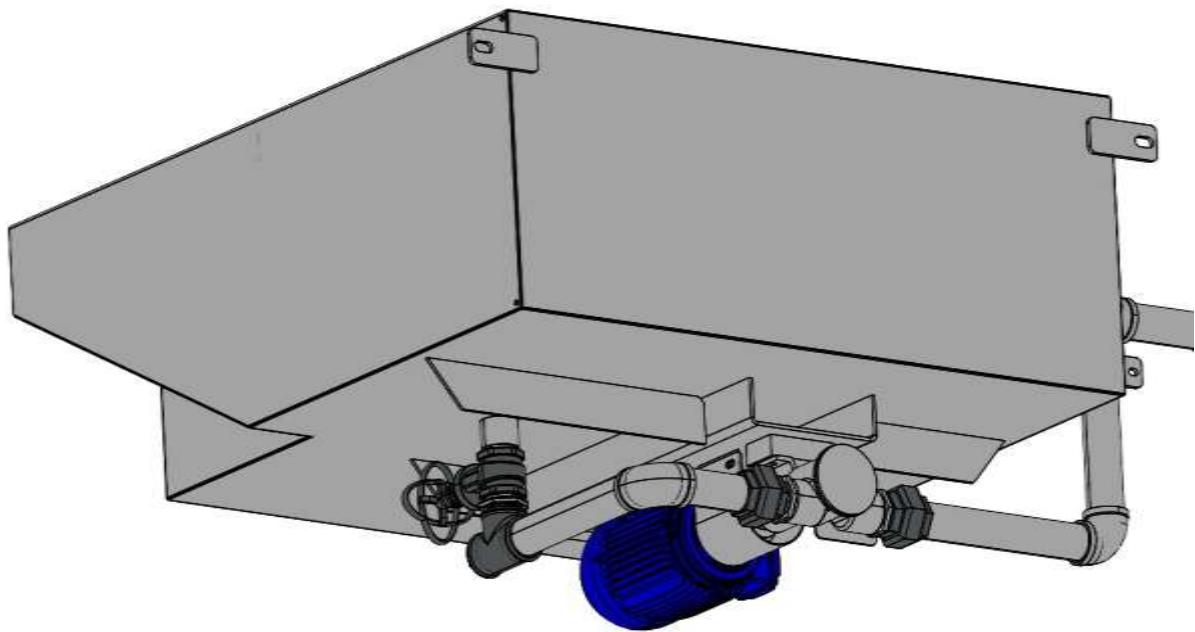

CEMENT WEIGH HOPPERS

CEMENT / BINDER WEIGH VESSELS:

Holding vessel fabricated from mild steel plate, with brackets for loadcells.

WEIGH SYSTEM:

Screw conveyors are mounted under the weigher. The vessel and screws are weighed to monitor the feed rate of the cement. The screws are tubular mild steel design with end seals and geared motor drive. Each screw feeds into both sides of the mixer ensuring good distribution of materials.

OUTLET:

A rotary valve on outlet controls feed into a twin outlet screw conveyor to discharge the cement or binder into the mixer. Feedrate is measured by recording rate of change of weight observed on the loadcells.

DIVERTER VALVE:

A diverter valve will be mounted above the hoppers to automatically divert material into which ever hopper is being filled, this is mounted independantly of the hoppers and will have no bearing on the overall weight being recorded by the loadcells.

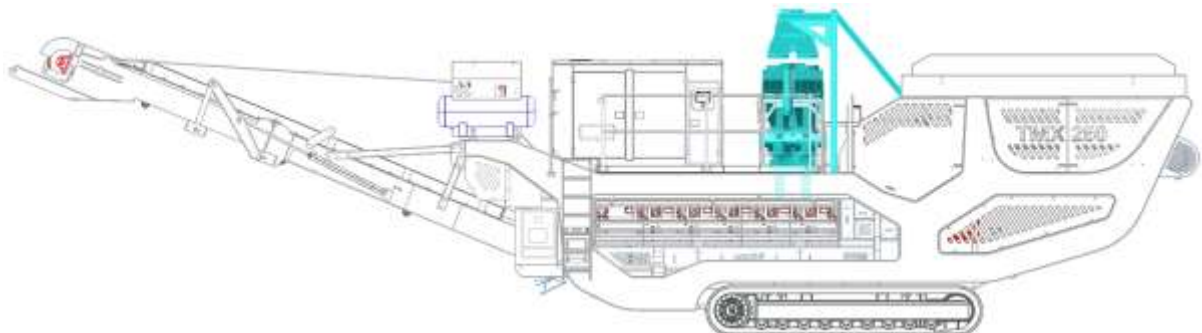
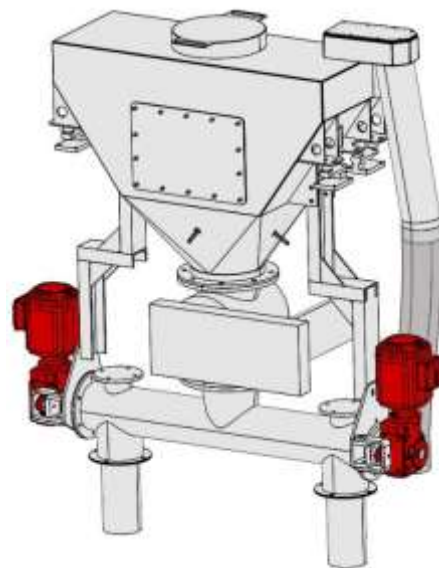

GENSET & CONTROLS

GEN-SET:

This unit provides electrical power for all machine functions. Diesel powered generating set rated at:



UK/Europe

TRAKMIX 250 152kVA 3 Phase, 50 Hz, 1500 RPM Emission Compliant for UK/EU at NTP Conditions.



Australia

TRAKMIX 250 155kVA 3 Phase, 50 Hz, 1500 RPM Emission Compliant for AUS at NTP Conditions.



North America

TRAKMIX 250 153KVA 3 Phase, 60 Hz, 1800 RPM Emission Compliant for US/ CANADA at NTP Conditions.

Each machine features:

- Heavy duty fabricated steel banded baseframe fuel tank with anti-vibration mounting pads.
- Electric starting system with heavy duty lead acid type starting batteries and battery charging system.
- Fuel feed and return lines from engine to 8 hour capacity baseframe fuel tank.
- Industrial exhaust silencer system (LRC) / SCR DOC (US) / SCR DPF (EU) Aftertreatment system.
- Automatic engine shutdown protection equipment with LED indicator for low oil pressure, high engine temperature, low coolant level, overspeed, and fail to start.
- Set mounted autostart control and instrument cubicle containing voltmeter with phase selection switch, ammeter with phase selection switch. dual scale frequency/ tachometer, water temperature gauge, oil pressure gauge, battery, voltmeter, hours run counter, 3 attempt starting timer, mode selector switch run/off/auto, emergency stop button, lamp test/reset button, terminals for remote start, remote emergency stop and common alarm signal. Set mounted circuit breaker cubicle containing suitably rated 3 pole moulded case circuit breaker.

NB: Rapid International's inhouse, Rapid Power Generation division can provide further specific Genset information and solutions to suit your requirements.

PLANT CONTROL SYSTEM:

The system uses an Allen Bradley Micrologix Processor to control all of the plant functions for automatic control with manual control backup via the touchscreen.

Control Panel: The operator control panel has push buttons and selectors to activate the genset and compressor etc. All automatic and manual control is provided by the HMI on the panel.



Automatic Control: A 15" touch screen HMI operator interface is used for operator inputs and display of all parameters. This interfaces with the processor to control the plant. A backup laptop PC is provided to enable the plant to be operated remotely (via WiFi connection).

Software Features: Storage of up to 50 Recipes: each recipe contains the details of a specific mix, which is the ratio of cementitious product to aggregate. Stock Control: cement stock and usage are stored in memory and may be displayed or printed out. Printer: the printer will record batches produced and a print will be given after each batch with details of material produced. Plant Alarms: an alarm message will be displayed on the HMI and a print-out given of the alarm fault together with date and time. (an audible and visual alarm is available where operator may be away from the panel and is still made aware of it.)

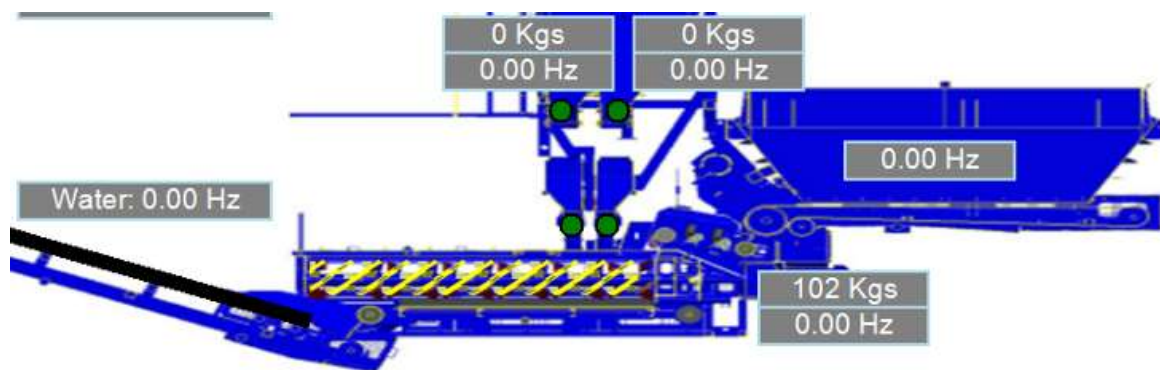

After the HMI powers up, the home screen (the running screen) is displayed. This screen is where the operator will gain the majority of the information when the plant is running.

Remote Access: a modem is fitted, that can be used to allow remote access for both management and our technical staff. We can assist with fault finding, download software updates. Client to supply 3G or WiFi connection to use this feature.

Starter Panels: The starter panels, house the starters for all of the drive motors on the plant and variable speed drives for the drives that adjust in operation.

Weighing: Compression loadcells monitor the weights of cement and aggregate.

Water Meter: Litre counter to measure the flow rate of water into the mixer.

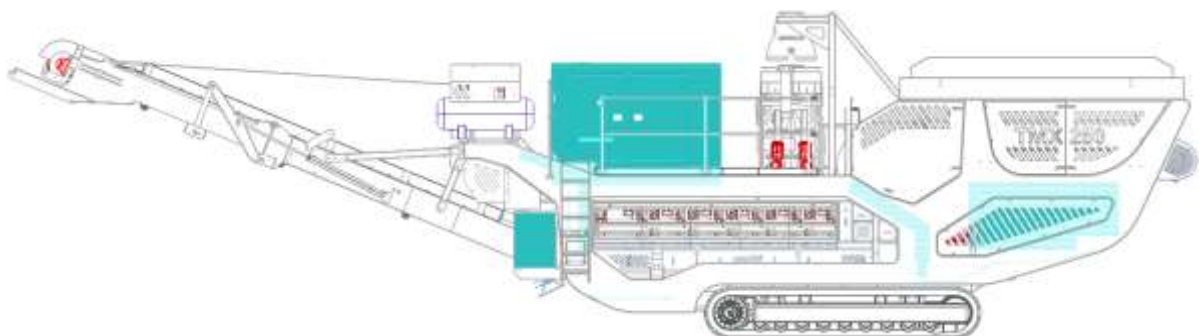

PNEUMATIC SYSTEM

PNEUMATIC SYSTEM:

hydrovane



- **Compressor:** The Trakmix is equipped with a Hydrovane HV04 504PURS10-4035D200 compressor to provide the air supply for the Gob Hopper doors silo aeration and the silo filter.

Max Working Pressure = 12 BAR (Safety Valve Setting)

Max Working Temperature = +110°C

Min Working Temperature = -10°C

Receiver Tank Capacity = 200 Litres

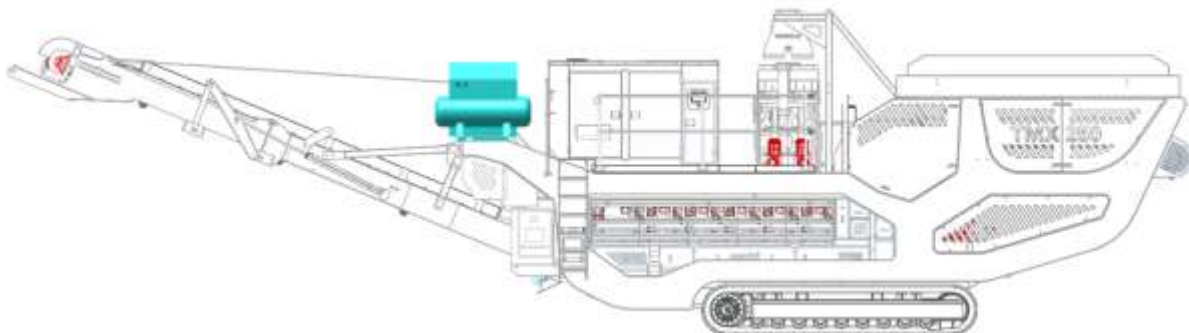

INTENTIONALLY BLANK

OPTIONS

OPTION 1 ADMIX SYSTEM

Litre counter and additive pump to measure the flow rate of additive into the mixer.

The Admixture Metering Systems are compact self-contained units that can accurately and very reliably dispense any amount of admixture.

The admixture metering system is based on microprocessor technology utilising an electrical pulse from the flow of admixture through a flowmeter.

Outputs Available:

- 12 LPM - transmitter options 33.3 or 100 PPL
- 28 LPM - transmitter options 10 PPL
- 50 LPM - transmitter options 10 PPL or 4 PPL

Electrical Specification:

- 12 LPM - Pump230/1/50Hz 0.18 Kw IP55 1.4 amps 1430 rpm
- 28 LPM - Pump230/1/50Hz 0.37 Kw IP55 3.3 amps 1420 rpm
- 50 LPM - Pump230/1/50Hz 0.75 Kw IP55 4.4 amps 2790 rpm

Reed Switch Maximum voltage 110v



SIZE	LENGTH	WIDTH	HEIGHT
12 LPM (Litres per Minute)	120cm	30cm	45cm
28 LPM (Litres per Minute)	125cm	30cm	45cm
50 LPM (Litres per Minute)	130cm	30cm	45cm

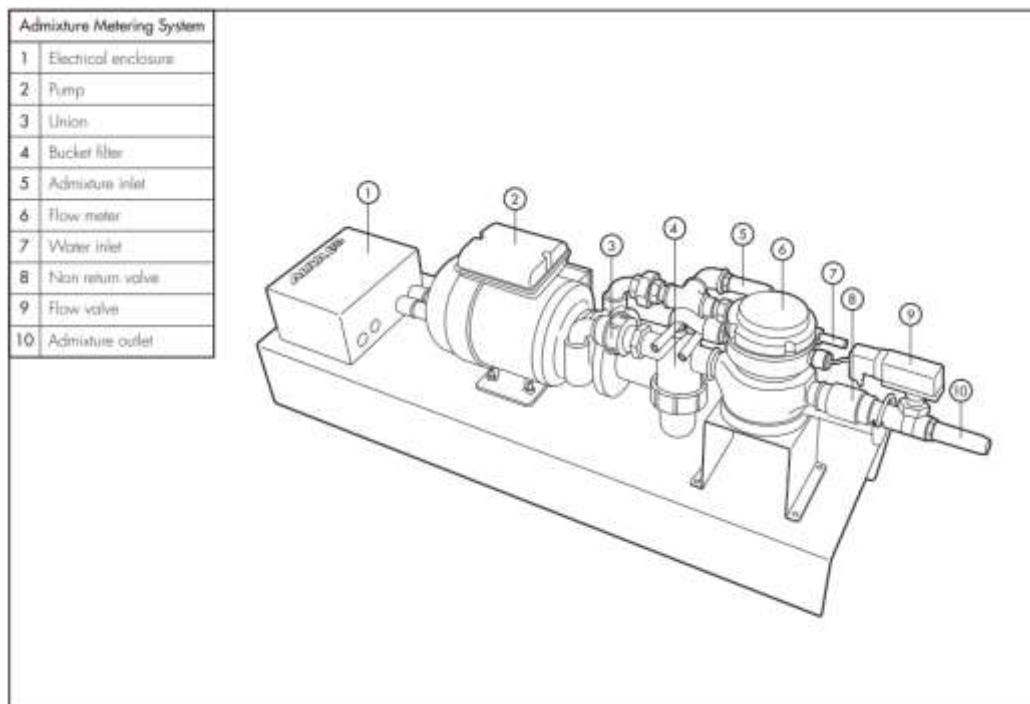

OPTION 1a MULTIPLE ADMIX SYSTEMS

Pneutrol can provide up to 4 x outputs in the PLC to control each of the 4 admixes – a separate output for each admix.

The user will define each admix material within the software, if the admix is used in the recipe, the output for that admix will be energised during the mixing process as would be normal, Pneutrol will then count and record the pulses from each admix and this will be stored in the production file for the loads being mixed. As each load is being mixed, the actual admix value used will be shown on screen – it is totally up to the operator to ensure this is set correctly to achieve the flow required. If the admix is not in line with the desired flow rate, Pneutrol are not to alarm, nor stop the machine.

All control of the admix, speed control, verification the admix is running, pumps, pulsers etc. to be supplied and installed by others.

Pneutrol assume there are enough spare inputs and outputs on the system to accommodate the changes required above. Pneutrol assume all site wiring and installation by others. Uploading of new programme to be done remotely via the modem link.

OPTION 2 AUXILLARY SILO

Silo options are available to accompany the Trakmix, preferred options are horizontal, however vertical silos are available in multiple sizes.

NB: the Auxiliary Silo is installed with the material added via volumetric feed control.



OPTION 2a AUXILIARY SILO 'SOFTWARE READY'

Rapid can prepare the Trakmix plant to be 'Auxiliary Silo' ready by having the plant's software and hardware setup in preparation for any future decision made by the user to add an Auxiliary Silo.

The plant would be prepared by means of a Power & Communications outlet to connect to the Auxiliary Silo from the Rapidmix plant.

OPTION 3 STATIC VIBRATING / HYDRAULIC GRID

Vibrating / hydraulic grid for aggregate hopper. Grid fitted to avoid oversized materials from entering the hopper.



OPTION 4 CHANGEOVER SWITCH

Rapid offers the opportunity to operate the Trakmix with 'Power Change-over' capabilities. The Power Change-over option allows the user to switch the power source to the plant from either the onboard Genset or by plug-in direct mains power supply.

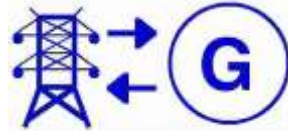

The Trakmix can be fitted with Power Change-over capabilities via the installation of a Changeover Switch. The Changeover Switch is supplied and installed by Rapid. Pneutral will install cabling to and from Changeover switch to leave the Trakmix, Power Change-over ready.

Trakmix– Main/Generator Manual Changeover Panel features:

- 1. 2 x 250Amp 4 Pole MCCB's for mains/generator incoming supplies.
- 2. 1 x 250Amp 4 Pole manual Changeover Switch C/W handle kit and terminal covers.
- 3. All inside a 800x600x250mm Deep Enclosure

OPTION 5 AGGREGATE BIN OPTIONS
OPTION 5a AGGREGATE BIN DIVISION PLATE REMOVAL

Rapid International can provide the option of having no aggregate bin division plate included with the Trakmix unit if preferred.



OPTION 5b MOISTURE PROBE(S)

Supply and installation of up to 2No Hydronix Moisture Probes to the aggregate storage bin.

The Hydro Probe II sensor is designed to give the greatest possible flexibility for measuring moisture content within aggregate storage bins and is the first microwave sensor to use digital measuring techniques, providing greater accuracy and range of measurement than any other sensor on the market.



The Hydro Probe II detects rapid changes in moisture content by sampling the material 25 times per second and then providing the Pneutrol Control system with a direct analogue signal allowing the water/weight compensation figure to be calculated.

Pneutrol Engineers will mount the probe and install all cabling

OPTION 5c VIBRATOR BIN CLEANING SYSTEM

Supply and installation of a Three-phase asynchronous electric Vibrator to the side of the bin to assist with the cleaning of material from within the bin.



OPTION 5d AGGREGATE BIN AGITATOR

Rapid can provide the option to include an Aggregate Agitator to the Aggregate Bin area of the Trakmix machine. The Agitator assists with breaking down and mixing clumpy/ difficult material together within the Aggregate Bin unit to promote a homogeneous mix before being conveyed to the mixing chamber.

The Aggregate Bin Agitator can be offered in a single or twin configuration.

Each Agitator is powered by a 5.5 kw electric motor and factory-made with serrated impellers attached all along the agitator shaft.

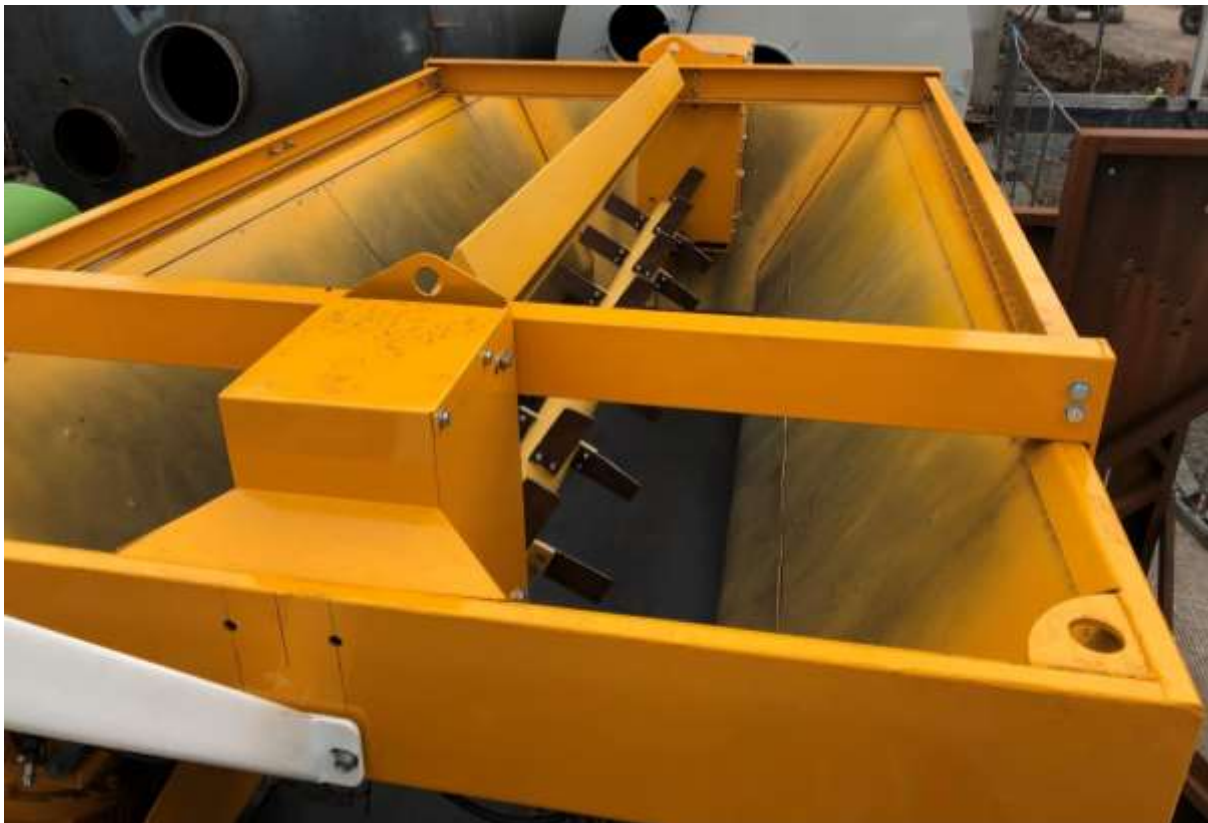
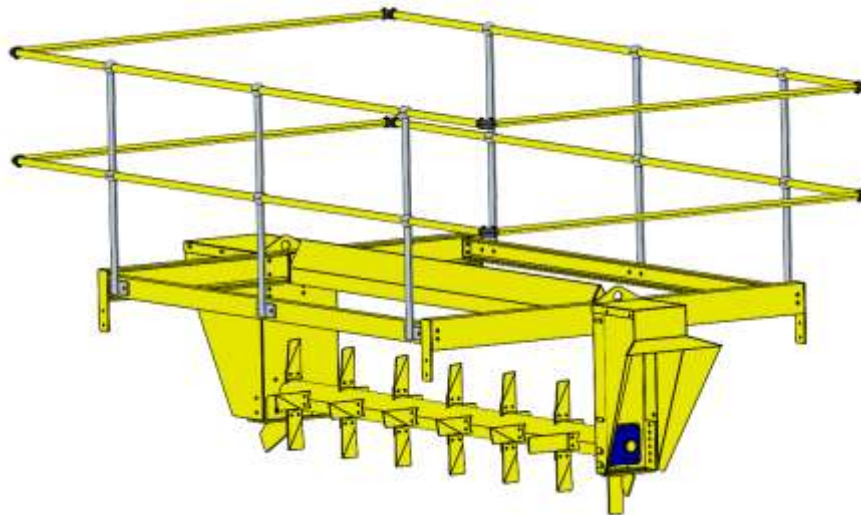

OPTION 6 GOB HOPPER ATTACHMENT

Option to have a Gob Hopper attachment added to the Outloading Conveyor discharge end
Gob Hopper gives the option to 'hold' material before being dispensed at a discharge rate selected by the operator

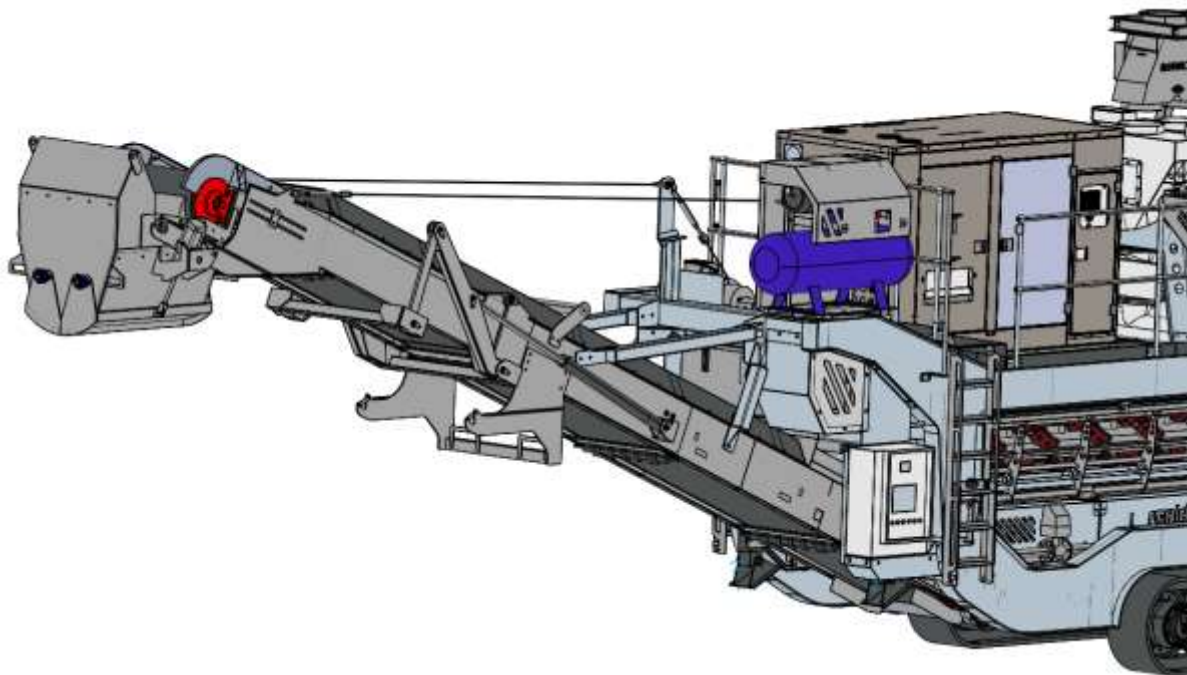
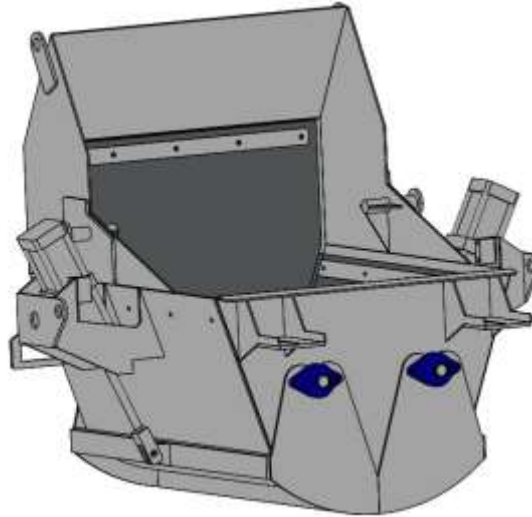

OPTION 7 CUSTOMISED PAINT COLOUR

The plant can be painted in any colour. Our standard colours will be applied if no colour is specified however for branding purposes customer colours can be used.

OPTION 7a ADDITIONAL DECALS

The plant can be customized to include decals of the company brand and business info.

Notes on our Quotation

1. None of the above prices include VAT or local taxes. VAT or the relevant tax will be added to these prices at time of ordering, where applicable.
2. All contracts are undertaken subject to our conditions of sale, available upon request.
3. Prices are valid for 60 days from date of quotation. After this date check with our sales department.
4. Customer to provide a clean supply of water at an adequate pressure and flowrate. Water systems are designed for clean water only unless stated otherwise in the quotation.
5. Cleaning: the mixer and all equipment handling concrete must be cleaned regularly (daily or more frequently depending on application) when in use. Any damage to equipment as a result of not being cleaned will invalidate warranty and all repair expenses will be charged to the client.
6. Any defect in equipment supplied must be reported to us in writing immediately. If the defect is not notified to us and is allowed to continue and cause damage to itself and/or surrounding plant, any repair expenses will be charged to the client.

CONDITIONS OF SALE

1. General

- 1.1 In these conditions (unless the context otherwise requires) the expression "Company" means Rapid International Ltd and the expression "Customer" means the person, firm or company to whom the tender /quotation is addressed or whose order is addressed or whose order is accepted by the Company.
- 1.2 These conditions shall be deemed to be incorporated into all contracts made by the Company and all work undertaken by the Company shall be deemed to be carried out pursuant to a contract incorporating these conditions notwithstanding anything to the contrary in the Customer's order.
- 1.3 No representative or agent of the Company has any authority to vary or add to these conditions. Any variation or alteration shall only be valid if authorised in writing; signed by a Director of the Company.
- 1.4 The Customer shall be liable to the Company as a principal for all costs, charges and expenses that shall be due to the Company in respect of work carried out by the Company subject to these conditions whether or not such Customer purports to contract as an agent. A Customer may not assign the benefit or burden of any contract with the Company.
- 1.5 Any tender or quotation by the Company shall be deemed to be withdrawn unless accepted within 30 days of the date thereof. No order shall bind the Company unless and until the Customer has received written confirmation from the Company.
- 1.6 Any information from the Customer necessary to enable the Company to proceed with any order must be furnished within a reasonable time otherwise the Company may at its option cancel the order or charge the Customer an additional fee for the delay.
- 1.7 The singular in all cases shall include the plural and vice versa.

2. PRICES

- 2.1 All published prices are subject to VAT where applicable and are subject to revision without notice.
- 2.2 Orders are only accepted on condition that they are executed at the prices ruling at the date of despatch.

3. CONDITIONS & WARRANTIES

- 3.1 Whilst the Company shall make every endeavour to use the best materials available no liability is accepted by the Company for any loss, damage or injury to property or persons, lost income or consequential financial loss, directly or indirectly from any failure or defect in the machinery or equipment shipped.
 - 3.2 The Company, at its discretion, undertakes to replace or repair free of cost any part or parts supplied by it direct to the Customer of which it shall receive written notice and which shall be proved to the satisfaction of the Company to be defective in workmanship or materials either within a period of twelve months (or 2000 verified operating hours) of delivery or if the Company is responsible for erection within a period of twelve months (or 2000 verified operating hours) from the date when the machinery is ready for starting and provided:
 - (a) The written notice of complaints is given to the Company within one day of the discovery of the defect.
 - (b) That the part is returned carriage paid to the Company.
 - (c) That the part, if replaced, shall become the property of the Company.
 - (d) That the Company shall not be liable for the cost, of removal of the defective part or the cost of fitting a new part.
 - (e) That the defect has not been caused by carelessness, improper or inadequate lubrication, inadequate maintenance or cleaning, or excessive use.
 - (f) No un-authorized alteration or modification has been made to the plant or machine or component subject to the claim.
 - 3.3 The new part will be delivered by the Company to the Customer's premises in the UK or port of exportation.
 - 3.4 In the case of parts or components not manufactured by the Company, the Customer shall be entitled to the benefits in so far as they may be transmitted to the Customer of any guarantees given by the manufacturer in respect thereof and the Company's liability in respect of such parts or components is limited to make the benefit of the manufacturer's guarantee available as aforesaid.
 - 3.5 In so far as permitted by statute or otherwise the guarantee contained in paragraph 3.2 above is in lieu of and excludes any other conditions or warranties expressed or implied statutory or otherwise and in no event shall the Company be liable (except to the extent, if any) of its undertaking or by statute as aforesaid for any loss, injury or damage howsoever caused or arising.
- ### 4. DRAWINGS, CAPACITIES, ETC.
- 4.1 Dimensions, details and statements as to the suitability of machinery for any particular purpose or as to the capacity, type or power specified or contained in any drawings, quotations, catalogues, shipping or other specifications etc., and any illustrations or photographs referred to, though carefully given are not intended as, and must not be treated as, the contractual description.
 - 4.2 The Company undertakes no responsibility for sites or foundations or any for any framework or support for machinery or compliance with any local By – Law or statutory regulations or for the fulfilment of any special requirements which the Customer may be bound to observe or fulfil. The Customer shall be responsible for the proper adaptation of any designs to his own circumstances

5. DELIVERY

5.1 The Company shall not be liable for delays caused by any of the following:

- (a) Industrial disputes.
- (b) Strikes.
- (c) Lock-outs.
- (d) Fire.
- (e) Accident.
- (f) Non-delivery or late delivery of materials or parts by other manufacturers.
- (g) Faulty castings or forgings.
- (h) Works breakdown.
- (i) Any other cause beyond the Company's control

5.2 Times and dates for delivery or performance are estimates only and not contractual obligations of the Company

5.3 The Company will make every endeavour to deliver by the time or date given, but accepts no liability for any loss caused by delay howsoever caused.

5.4 If the Customer shall be unable or unwilling to take delivery when the goods or part thereof are ready for despatch, then the Customer shall pay to the Company a reasonable charge for storage until such time as he is able and willing to take delivery of such goods or part thereof. Any payments due but delayed because the Customer is unable or unwilling to take delivery shall, if not already due, fall immediately due.

6. TRANSIT

6.1 Notwithstanding anything in the tenders, quotations, order or contract, as to the place of delivery, or payment of carriage the Customer agrees that any goods in transit shall be at his risk, and accordingly all consignments shall be deemed to be in the Customer's possession (whether the property therein shall have passed or not) after a despatch from the Company's premises.

6.2 All shipping delays, demurrage charges and shipping charges of any description, after the Company has fulfilled its obligation (if appropriate) to deliver to United Kingdom docks, shall be at the Customer's expense.

6.3 All unloading shall be at the risk of and expense of the Customer, except when the Company is contracted to erect the machinery.

6.4 The Customer shall keep goods fully insured and shall, if appropriate indemnify the Company against any loss or damage.

7. PACKING

All machinery shall be freighted open with small component parts crated unless specifically requested on the order "to be crated." Packing cases on all exports will be charged to the Customer at cost.

8. COMMISSIONING

8.1 Where the Company's sale includes commissioning the Company accepts no contractual obligation in respect provision of work or materials for the preparation of a proper site with suitable and sufficient access thereto. Unless otherwise expressly agreed in writing the Customer shall be responsible for and bound to provide at his own expense:

- (a) A properly prepared, safe, site, with suitable foundations and adequate access and hard-standing for vehicles and plant.
- (b) All necessary lifting tackle, raw materials for the process involved, fuel, water, oil and other stores and,
- (c) Also sufficient labour and assistance to enable the Company to proceed properly with and complete the erection of and the starting and setting to work of the machinery.

8.2 If the Customer shall require training for his personnel he shall provide operators of acceptable calibre and physical capability to the Company, who shall provide suitable training at the Customer's expense. If necessary an interpreter shall be made available at the Customer's expense. The Customer shall indemnify the Company against any claims, damages, costs and expenses in respect of any accident, injury or loss sustained by personnel recruited by the Customer and arising out of and in the course of training of such personnel by the Company. The Customer shall on recruitment of such personnel effect the necessary employer's liability insurance in respect of them.

8.3

8.4 Prices quoted for erection are based on the Company's normal order and acceptance terms. Overseas travel of the Company's employees; board and keep shall be the responsibility of the Customer unless specific alternative arrangements are agreed in writing between the Customer and the Company.

9. PATENT RIGHTS

The Customer shall indemnify and keep indemnified the Company against all claims, damages, costs and expenses to which it may become liable through executing an order in accordance with the Customer's specification which constitutes an infringement of any patent or registered design.

10. PAYMENT

10.1 Payment shall be made net to the Company's head office or its appointed bank upon notice of the goods being ready for collection or despatch. Cheques, money orders, BACS or other negotiable documents must be made payable to the Company and only the Company's official receipt shall be valid. For export orders payments shall be in Sterling or in a currency specified by the Company against shipping documents at a bank in the United Kingdom, unless expressly stated otherwise by the Company.

10.2 The contract price will be payable by the Customer in strict accordance with the contract terms, notwithstanding any delay in delivery or performance on the contract or any adjustment or correction for minor defects which may be required to the plant machinery or work. The Company may suspend performance on any contractual obligation to the Customer so long as any account of the Customer is overdue.

10.3 Daily Interest at 5% APR will be charged, at the Company's discretion, on all overdue accounts, until the payment is confirmed in our bank account.

10.4 In no case, will the property in any goods pass to the Customer (notwithstanding that possession or risk shall have passed to the Customer) until payment has been made to the Company for the full contract price of the goods, including the price for erection or other work or services (if any) to be done by the Company.

10.5 In case of default by the Customer after the delivery of any goods and before the goods have become the Customer's property the Company may give notice to the Customer terminating the Customer's rights to possession where upon the Customer shall be bound, at his expense, to return the goods to the Company. In all such cases the Company may (whether with or without previous notice) itself retake possession of the goods and the Company is in such circumstances irrevocably authorised by the Customer to enter the premises on which the goods are situated and to dismantle and remove the goods from the same at the Customer's expense.

11. SAFETY

To the best of the Company's knowledge the machinery and plant manufactured by the Company complies with the requirements imposed on a Manufacturer under the regulations enforced in the United Kingdom or any part thereof. Should special or additional guards be required to meet the particular local requirements of the Customer they will be charged as additional items.

12. JURISDICTION

This contract is governed in all respects by the law of Northern Ireland within the United Kingdom and the Customer Submits to the Jurisdiction of the Courts of Northern