

RAPIDMIX

MOBILE CONTINUOUS MIXING PLANT



RAPIDMIX OVERVIEW

The Rapidmix is the culmination of 20 years research and development and delivers the most accurate, reliable and powerful mobile continuous mixing technology to a wide range of end users worldwide.

Rapid International's Rapidmix machine is designed to offer unrivalled production throughput and application flexibility.

Producing outputs from 400 up to 600 tonnes of material per hour, the Rapidmix delivers speed and cost efficiency. Fully mobile and self-contained, the Rapidmix travels from site to site with ease.

The robust design with optional features such as mobile aggregate bins or power source changeover to name a few, make the Rapidmix the most versatile mobile pugmill on the market today.



Tier 3, 4 or 5 Diesel powered by world renowned engine brands, combined with powerful hydraulics and auto feeder speed control guarantee the machine is always functioning at its optimum level.

The plant is controlled by a highly intelligent and robust PLC Processor to control all of the plant functions for automatic control with manual control backup via the HMI touchscreen interface. Software features include the option to store up to 50 recipes detailing specific mixtures, stock control, batch recording printer, and plant alarms.



Rapidmix Applications:

- Mixing roller compacted concrete (RCC)
- Bentonite land fill sealing
- Airport runway construction
- Contaminated land treatment
- Mine backfill
- Cement treated base (CTB)
- Environmental remediation
- Soil stabilisation
- Dam construction works
- Paving quality concrete
- Soil cement
- Cold mix (foamed Bitumen), and many more



RAPIDMIX RANGE

TECHNICAL SPECIFICATION

MACHINE ATTRIBUTES	UNITS	400CV	600CV	400CW	600CW
Output Rate Per Hour	Tonnes/hr	400	600	400	600
Weight	Kg	38000			
	Tonnes	38			
	Lbs	83776			
Transport Length	mm	18500			
	m	18.5			
	ft	60.8			
Transport Width	mm	3000			
	m	3			
	ft	9.1			
Transport Height	mm	4000			
	m	4			
	ft	13.1			
Working Height	mm	13000			
	m	13			
	ft	42.8			
Aggregates Storage Capacity	No.	2 (w/ division plate installed)			
Aggregate Hopper Capacity	m ³	12			
	yds ³	15.6			
Aggregate Weigh Belt Feeder		-	-	✓	✓
Onboard Genset Power	kVA	260	350	260	350
	HP	350	470	350	470
Onboard Water Tank Capacity	Litres	1600			
	US Gallons	423			
Cement (Binder) Silo Capacity	Kg	40000			
	Tonnes	40			
	Lbs	88185			
Out loading Conveyor Width	mm	800	1000	800	1000
	m	0.8	1.0	0.8	1.0
	ft	2.63	3.28	2.63	3.28
Cement Feeder Type:		-			
Rotary Valve	-	✓	✓	-	-
Cement Weigh Hopper	-	-	-	✓	✓
MIXER ATTRIBUTES	UNITS	400CV	600CV	400CW	600CW
Type		Twin Shaft Paddle Mixer			
Mixing Characteristics		Continuous Mixing			
Motor Drive Quantity	No.	1	2	1	2
Motor Drive Power	kW	75	45	75	45
	HP	100	60	100	60

Specification subject to change without notice

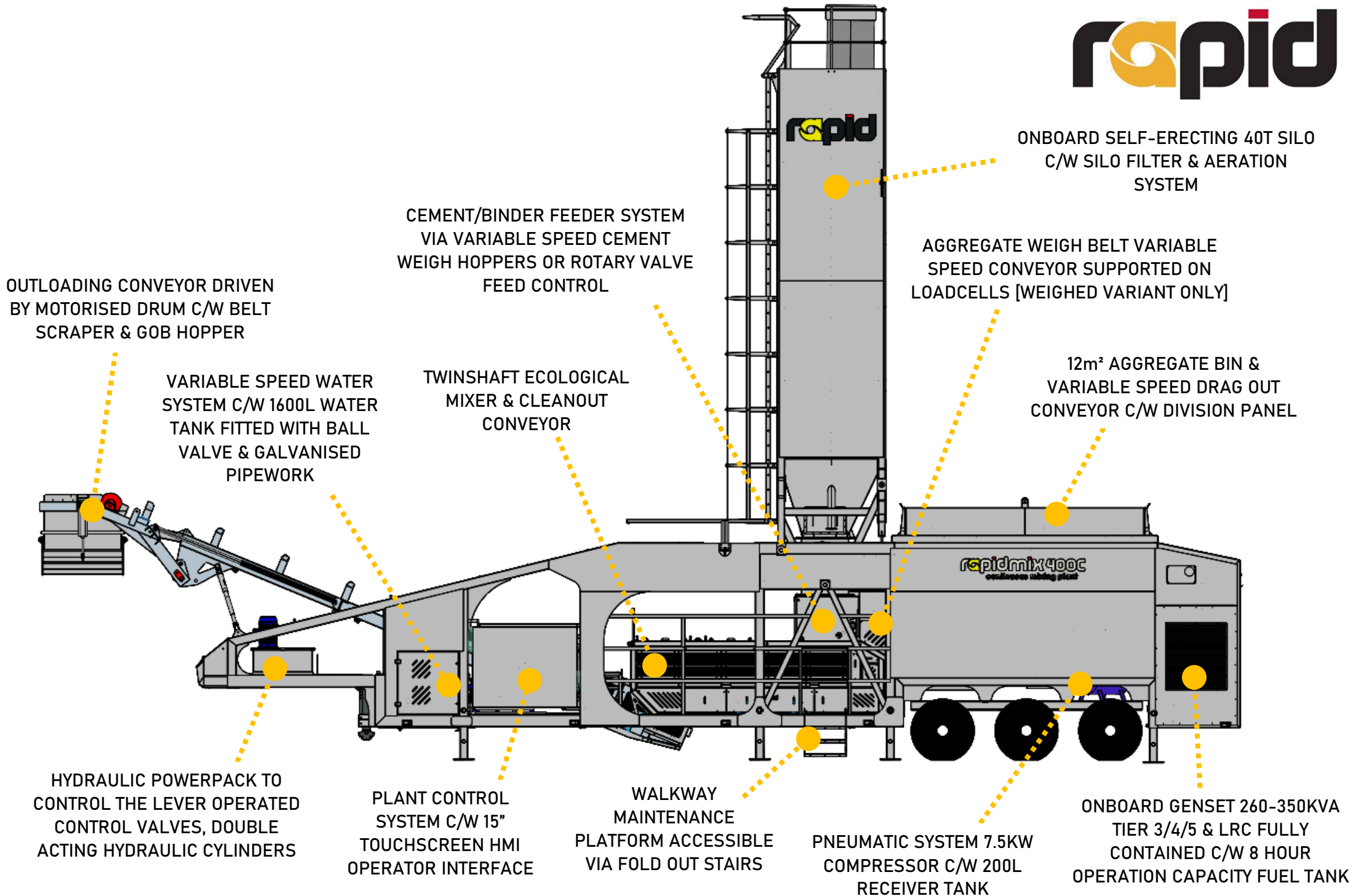

RAPIDMIX OPTIONS

ADMIX SYSTEM
Outputs available: 12 LPM or 50 LPM (Litres per Minute) as Self-contained units
Up to 4 Admix systems can be installed with separate outputs
AGGREGATE BIN OPTIONS
Option to have no aggregate bin division plate included on plant
Optional Hydronix Moisture Probe(s) to the aggregate storage bin (Quantity of up to 2 can be fitted)
Option to have an Aggregate Bin Agitator (Single or twin configuration) installed within the bin area
Optional installation of a Vibrator bin cleaning system (Quantity of up to 2 can be fitted)
HOPPER GRID OPTIONS
Optional Static grid fitted to aggregate bin opening to manage oversized/clumpy materials from entering the hopper
Optional Vibrating grid fitted to aggregate bin opening to manage oversized/clumpy materials from entering the hopper
Optional Tipping grid fitted to aggregate bin opening to manage oversized/clumpy materials from entering the hopper
COLD FEED BINS (MOBILE OR STATIC CONFIG.)
2, 3 or 4 bins available in a fully mobile or static configured unit allowing for additional aggregates to feed the Rapidmix.
RAPID SUPPLIED AUXILLARY SILO
Option for a standalone auxiliary silo manufactured by Rapid to allow further storage options. The silo can be made mobile.
Material added from the silo via volumetric feed control
AUXILLARY SILO 'HARDWARE READY' OPTION
Option to have the Rapidmix hardware ready for any future decision to connect an Auxiliary Silo via built in Power & Communications outlets from the Rapidmix.
POWER CHANGE-OVER SWITCH
Option to switch plant power source from Genset to direct mains power supply and vice-versa
LONGER CABLES FOR CONTROL PANEL
To incorporate plugs and sockets into the electrical cabling at the control panel with longer cable lengths
Lengths of cable available: 10m (32ft), 20m (65ft), 30m (98ft) cable run
DOMESTIC APPLIANCE DOUBLE SOCKETS
Rapid can deliver the option to have domestic appliance graded Double Sockets mounted within the panel to enable the customer to plug in appliances.
Rapid provide a 1kVA Transformer with circuit protection on primary & secondary of transformer
Sockets can be fitted to suit supply voltages for the following regions: USA, Canada, Australia, UK & EU
SOFTWARE UNITS DISPLAY
Rapid can offer to display all the units and figures that appear on the control panel in either Imperial units (ft or lbs) or Metric units (m or kgs)
CUSTOMISED PLANT
Customer brand colours and additional decals can be used if specified.

CONTACT US:

**Rapid International Ltd.
96 Mullavilly Road
Tandragee
Craigavon
Northern Ireland
BT62 2LX**

**Tel: (+44) 028 3884 0671
Fax: 028 3884 0880**

Dealer Stamp:

May 2024. The material in this document is for information only and is subject to change without notice. Rapid International assumes no liability resulting from errors or omissions in this document, or from the use of the information contained herein. Due to continual product development, we reserve the right to change specifications without notice. Any product performance figures given in this brochure are for guidance purposes only. This information does not constitute an expressed or implied warranty or guarantee, but shows text examples provided. Photographs are for illustrative purposes only. Some or all of the machines in the illustrations may be fitted with optional extras.

TYPE: RAPIDMIX –

600CV (Continuous Mixing - Volumetric)

OVERALL WEIGHT (EMPTY): 38 Tonnes (38,000 kg) (83,776 lbs)
WEIGHT ON REAR TRI-AXLES: 26.3 Tonnes (26,350 kg) (58,092 lbs)
WEIGHT ON FRONT PIN: 11.3 Tonnes (11,350 kg) (25,022 lbs)

TRANSPORT DIMENSIONS:

	mm	m	ft
Height:	4000	4.00	13.12
Width:	3000	3.00	9.84
Length:	18500	18.50	60.70

WORKING DIMENSIONS:

	mm	m	ft
Height:	13000	13.00	42.80
Width:	3000	3.00	9.84
Length:	20400	20.40	66.93

OUTPUT PER HOUR: 600 TPH

TRANSPORTING THE RAPIDMIX:

The Rapidmix is easily transported thanks to its 'hitch on - hitch off' kingpin, and its trix-axle wheel chassis; similar to that like any standard haulage semi trailer.

(RO-RO = Roll On – Roll Off Cargo)

TRANSPORTATION BY TRACTOR UNIT (LORRY)



TRANSPORTATION BY RO-RO CARGO SHIPPING TRACTOR UNIT (LORRY)



TRANSPORTATION BY RO-RO CARGO TRAIN



CHASSIS

Hollow section members fully welded into Lattice design with brackets fitted for attaching bin, silo, conveyors, mixer, and all ancillary items which make up the plant.

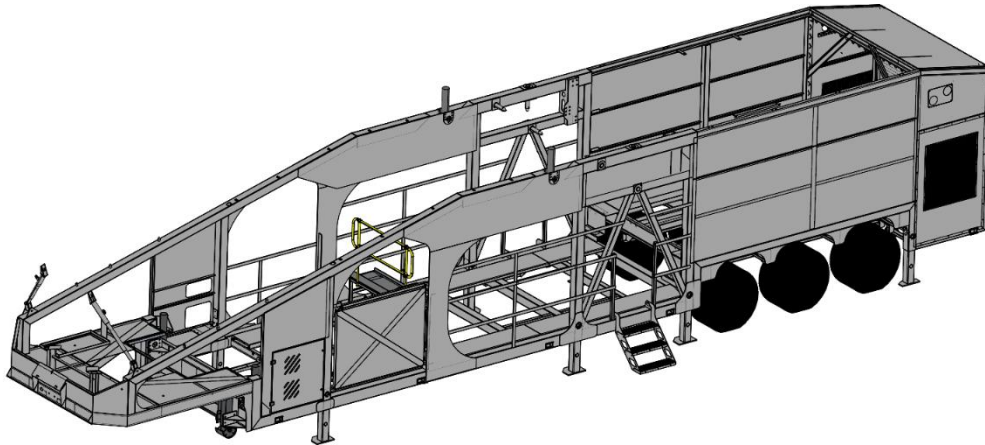

- AXLE TYPE:** Standard tri-axle.
- SUSPENSION:** Single leaf steel spring
- BRAKES:** Standard air operated hub brakes with automatic slack adjusters.
- WHEELS:** Twin wheels on each hub, (4 per axle total 12 tyres)
- LIGHTS & MARKINGS:** Rear marker lights, including indicators, brake lights and side markers in accordance with the regulations set by the plant operating location.
- ACCESS:** Walkways are provided along the chassis of the machine for maintenance access. The walkways are constructed from chequered aluminium material with handrails at appropriate points. Fold out stairs for access.
- HYDRAULIC RAMS:** Hydraulic Jacks are fitted to lift the machine after it is parked on the site and allow it to be leveled and secured into position on the support legs. Hydraulic rams then lift the silo and the outloading into the working position.

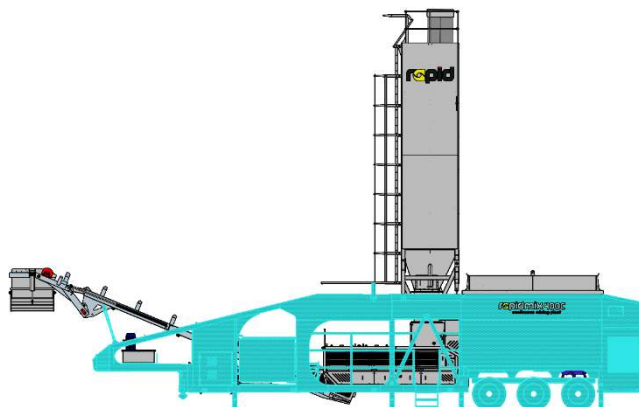

AGGREGATE HOPPER

- CAPACITY:** 15.6 cu yds (12.0 m³)
- LOADING WIDTH:** 14 ft 2½ ins (4330 mm). The hopper can be loaded from either side of the machine
- CONSTRUCTION:** S275 plate with stiffening ribs. Steep sides for difficult materials. (end slopes of 60 degrees).
- REMOVEABLE DIVISION PLATE:** The hopper has a removable division plate, allowing two materials to be used.
- LINING:** To aid the discharge of the materials the hopper surfaces are fitted the low friction high molecular polyethylene lining material (1/2" (12mm) thickness).
- ADJUSTABLE GATES:** The outlet end of the hopper is fitted with adjustable level gates to enable the material height on the conveyor belt to be varied. These are adjusted manually.

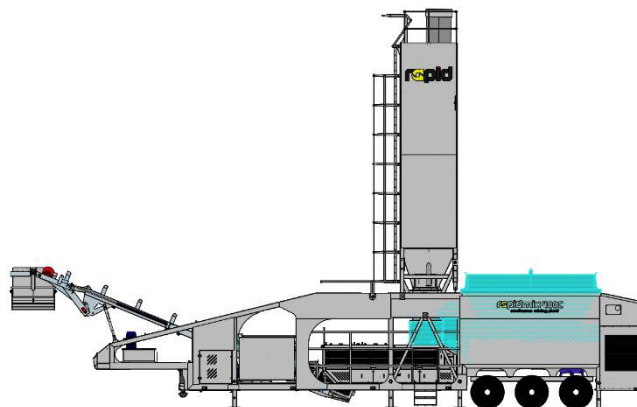
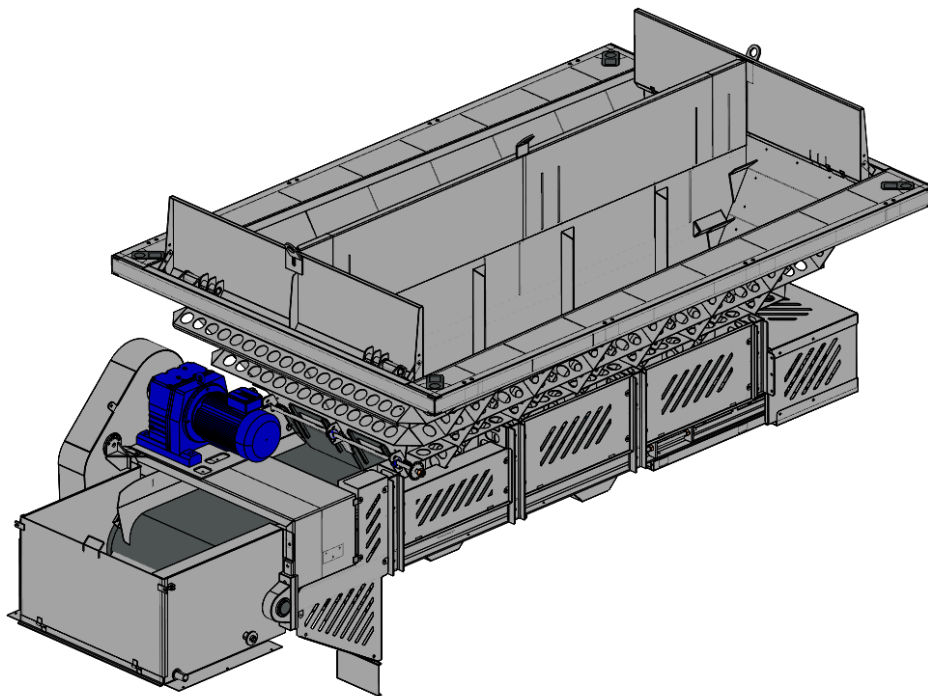

AGGREGATE BIN BELT FEEDER:

DESIGN: A Conveyor belt feeder is fitted on the bottom of the hopper to provide feed from the hopper to the mixer. The conveyor is fitted with adjustable rubber skirts and additional heavy duty support rollers.

CONVEYOR MOTOR 1No 22Kw heavy duty geared electric motor drive with automatic variable speed control attached to a lagged head drum.

BELT WIDTH: The belt width is 1200mm (4') and a heavy duty 3 ply belt is fitted.

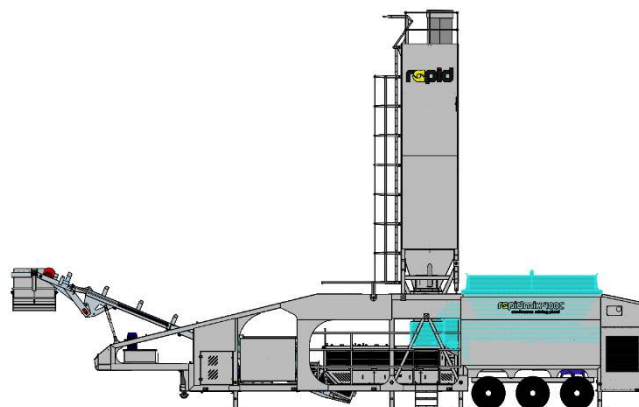
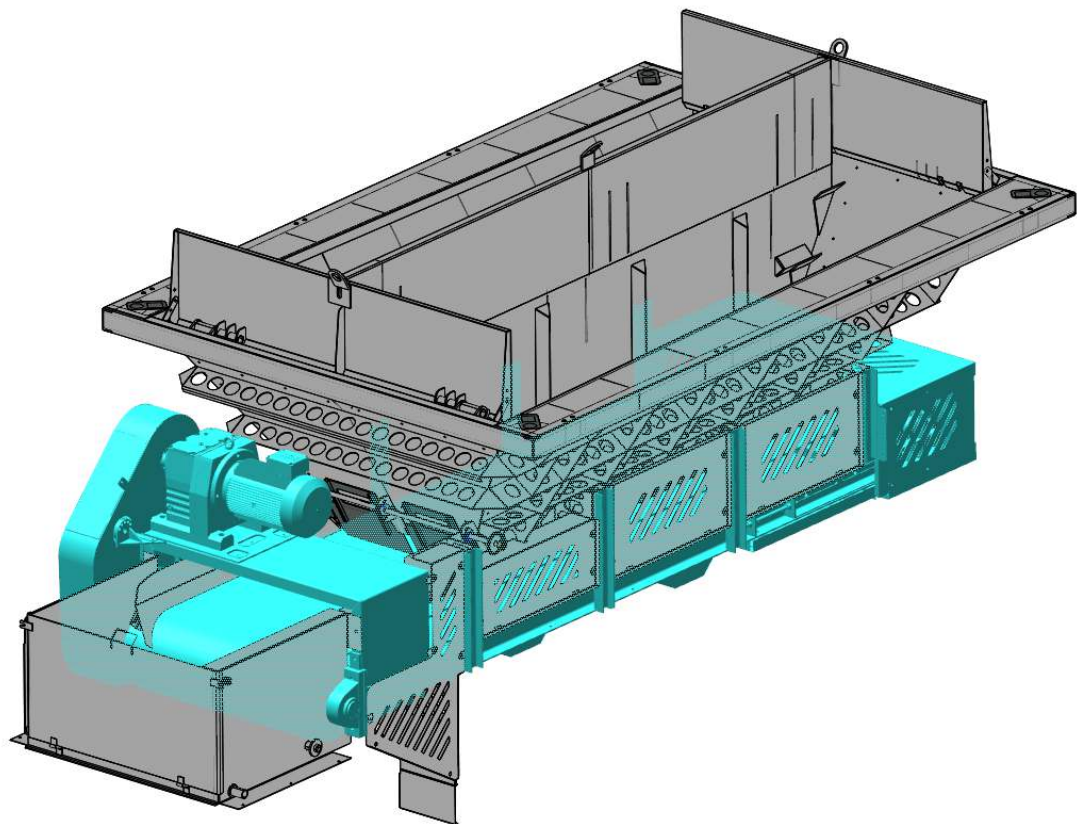

PUGMILL MIXER

TWIN SHAFT CONTINUOUS MIXER:

- MIXING ACTION:** The twin shafts mix the material, whilst moving the material toward the end of the mixer.
- MIXING PADDLES:** The twin horizontal mixing shafts are fitted with chill cast steel paddles, which are intermeshed in a specially phased relationship to optimise mixing action, whilst maximising throughput.
- ACCESS:** Special attention has been paid to give the user maximum access for maintenance and cleaning operations. The top of the mixer is fitted with hinged access covers, which when opened give access to all of the mixing chamber. Both sides of the mixing chamber hinge down, to give access, the sides are lowered by hydraulic cylinders.
- DRIVE:** The shafts are driven by 2No 45 kW (60 HP) electric motors through a reduction gearbox with twin gears to synchronise the shafts.
- MIXING CHAMBER:** The mixing chamber is formed by fabricated sloped sides with a troughed conveyor under the mixer forming the bottom of the mixer.
- WATER ADDITION:** Water spray bars fitted into the top of the mixer allow the water to be added to the material as it progresses along the mixer.

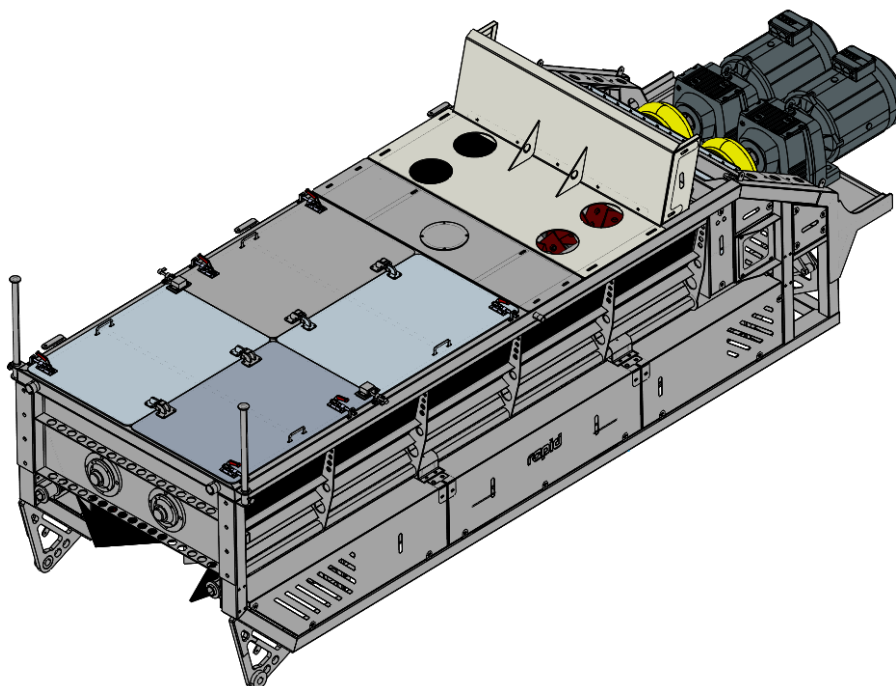

CLEAN-OUT CONVEYOR UNDER MIXER:

Mounted on the bottom of the mixer, forming the bottom of the mixing chamber, this conveyor allows the bottom of the mixer to be easily cleaned out, when production is finished. This conveyor is used for clean out purposes only. The mixer should be lined with a bed of material every morning before production starts. The conveyor is fitted with a low speed geared motor drive.

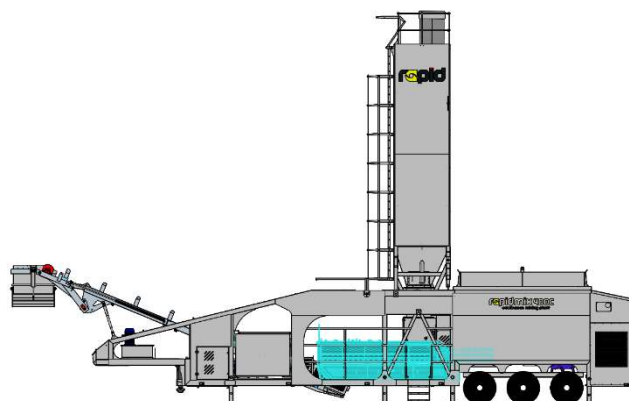
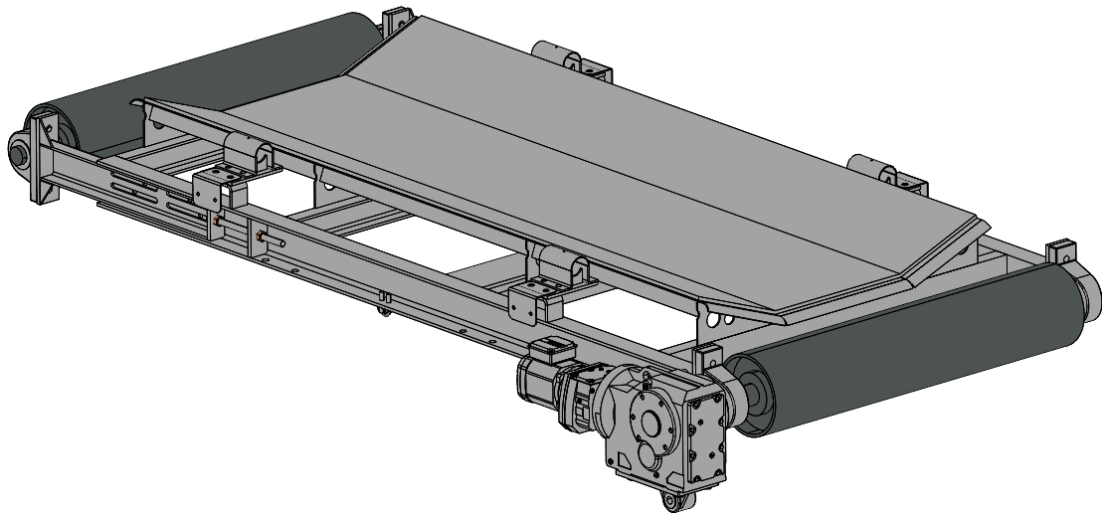

ONBOARD SILO

- CAPACITY:** 44 US Tons (40 Tonnes) based on material being 1400 kg/m³ (90lbs/ft³).
- CONSTRUCTION:** Square silo design constructed from all welded box section S275 plate with stiffening ribs.
- ACCESS TO ROOF:** By folding access ladder with safety cage, to the roof level, which is fitted with double tubular handrail and kicking strip. An access hatch is provided on top of the silo.
- OUTLET:** Flanged for the rotary paddle feeder.
- SILO VENTING:** 24m² Reverse Jet Filter. A pressure relief valve is fitted to protect the silo from over-pressurisation.
- FILLING PIPES:** 2No 4" (100mm) steel pipe with screwed end for fitting unicone or other type of delivery hose fitting.
- LEVEL INDICATION:** Rotating paddle style level probes for high- and low-level control.

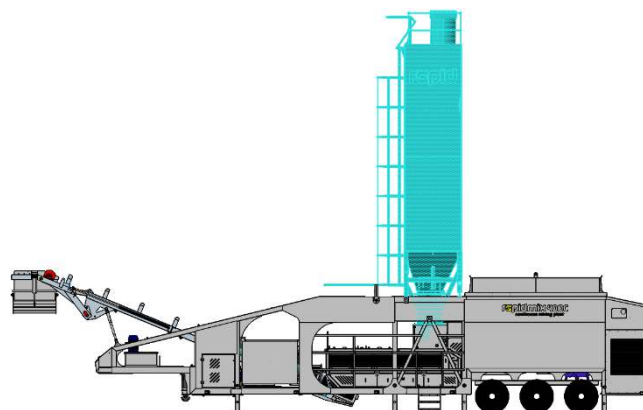
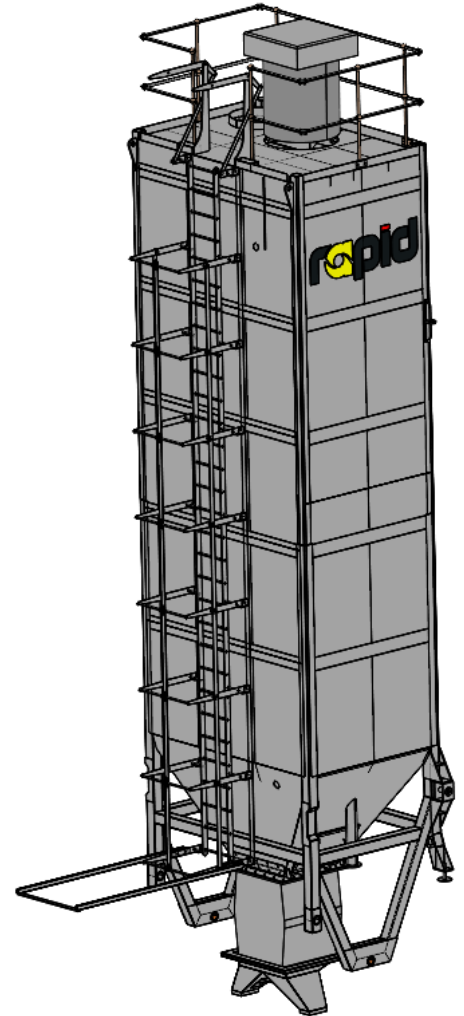

BINDER FEED SYSTEM _____

- DRIVE:** 2.2 kW (3 HP) geared electric motor with automatic variable speed control.
- TYPE:** Square rotary valve paddle feeder to feed the cement or binder material out of the silo.
- AIR PURGE SYSTEM:** The air purge system blows pressurized air through the rotary valve to keep material flowing smoothly, and prevents abrasion and related issues.

Air Pressure Delivery = 1.5 BAR

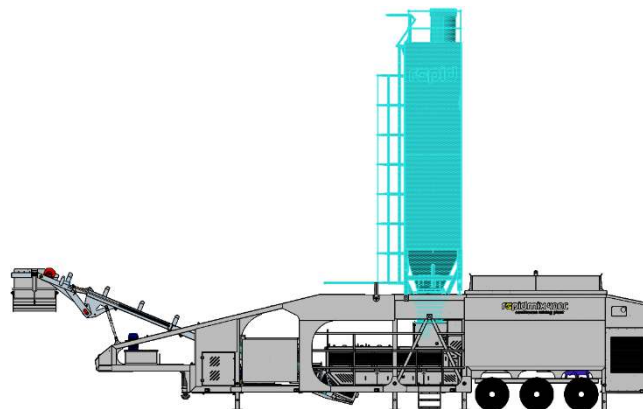
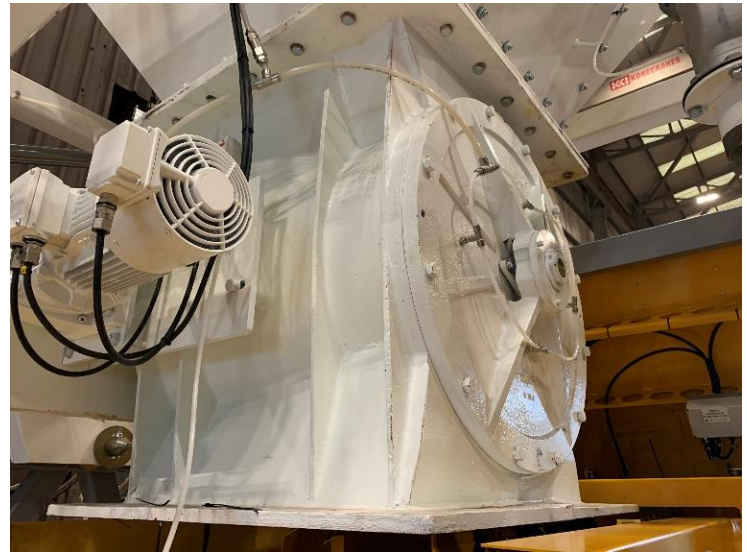

OUTLOADING CONVEYOR

Transporting the mixed material from the twinshaft mixer to the truck. The conveyor is designed to handle the maximum feedrate from the mixer. A Gob hopper fitted to the top end of the conveyor allows some mixed material to be “held” for a short time, for example whilst the next truck drives under for collection.

- CONSTRUCTION:** Box section S275 steel construction with mounting brackets for rollers and pivot mechanism. The top section of the conveyor incorporates a folding section for transportation.
- BELT:** 1000mm (31.5”) 3 ply belt with heavy duty top cover and vulcanised joint.
- DRIVE:** Motorised drum with rubber lagging.
- BELT SCRAPER:** Polyurethane blade pre-cleaner scraper mounted on the face of the head drum.
- GOB HOPPER:** Hopper fitted to the top end of the conveyor with pneumatic discharge doors. Constructed from S275 plate.
- BELT SCALE WEIGHER:** To continuously measure and report flow rates and totalized amounts of materials being transported on the Out-loading Conveyor belt. The weight of the material transported is determined by weighing the belt load and measuring the belt speed.
- *Standard on North America machine variant only**

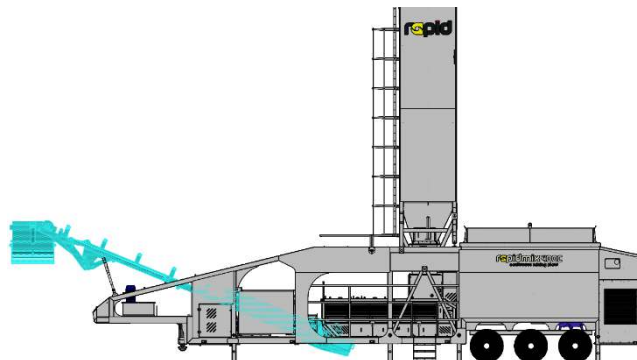
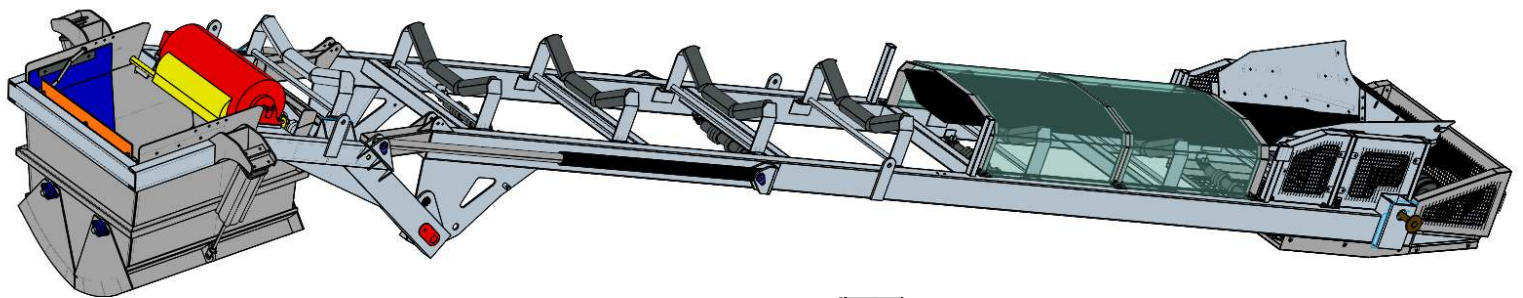

WATER SYSTEM

- WATER TANK:** A 1600 litre (423 us galls) is fitted complete with ball valve and galvanised steel pipework.
- PUMPS:** Two positive displacement pumps are fitted to supply 2No water spray bars within the mixer.
- SPRAY BARS:** Each Mixer spray bar has a ball valve to allow addition of water early in the mix, later in the mix or both together. A calibration point for accurate water weighing is also included.

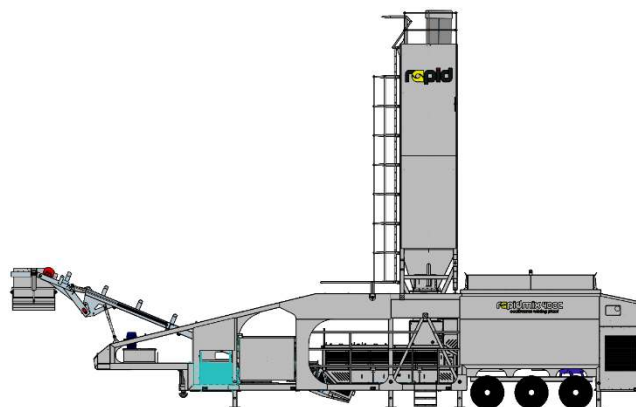
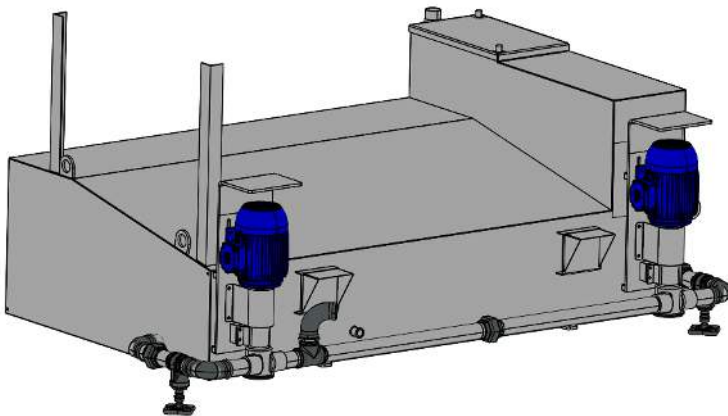

PNEUMATIC SYSTEM

The Rapidmix is equipped with a Hydrovane HR07PR10-4035S100 compressor to provide the air supply for the Gob Hopper doors, silo aeration and the silo filter. The air compressor is also fitted with a heavy duty filter as standard.

MAX WORKING PRESSURE: 12 BAR (Safety Valve Setting). 10 BAR recommended working pressure.

MAX WORKING TEMPERATURE: +110°C

MIN WORKING TEMPERATURE: -10°C

RECEIVER TANK CAPACITY: 200 Litres

VALVES & REGULATORS: Solenoid spool valves are fitted for the control of the Gob Hopper doors. A lubricator is provided for the Gob Hopper cylinders. A regulator (with pressure gauge) is provided to adjust the pressure as required.

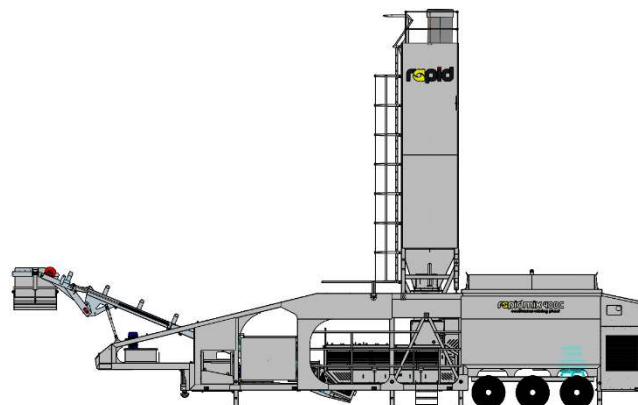

HYDRAULIC SYSTEM

The hydraulic system is used to level the machine before erection to the working position and also to erect the silo and out-loading conveyor. Also used for opening mixer sides for maintenance.

HYDRAULIC POWERPACK:

This consists of: Electric motor close coupled to a hydraulic pump unit, Oil reservoir, return line filter, directional valve, filler/breather, level gauge.

CONTROL VALVES:

Lever operated valves for operating the cylinders.

HYDRAULIC CYLINDERS:

Double acting type used on: Jacking / Leveling, silo elevation, out-loading fold-out, mixer sides.

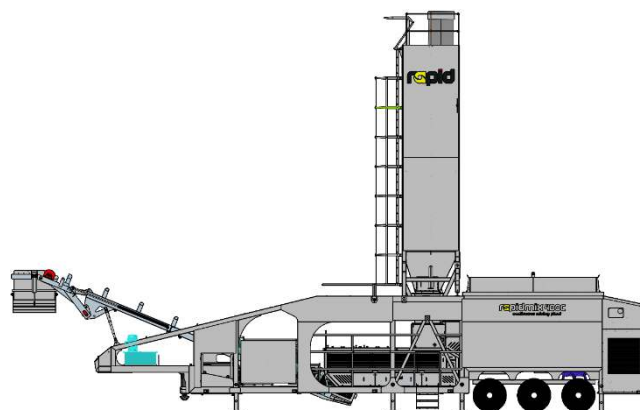

GENSET & CONTROLS _____

This Diesel-powered generating set unit provides electrical power for all machine functions.



RMX600C 350kVA 3 Phase, 50Hz, 1500RPM Emission Compliant for EU/UK at NTP Conditions.



RMX600C 350kVA 3 Phase, 50Hz, 1500RPM Emission Compliant for AUS at NTP Conditions.



RMX600C 350kVA 3 Phase, 60 Hz, 1800 RPM Emission Compliant for US/CANADA at NTP Conditions.



NB: Rapid International's sister company, Rapid Power Generation division can provide further specific Genset information and solutions to suit your requirements.



GENSET FEATURES:

- GENSET DESIGN:** Heavy duty fabricated steel banded baseframe fuel tank with anti-vibration mounting pads.
- START-UP:** Electric starting system with heavy duty lead acid type starting batteries and battery charging system.
- FILTERS:** High-capacity air, fuel and lubricating oil filters.
- FUEL TANK:** Fuel feed and return lines from engine to 8-hour capacity baseframe fuel tank.
- EXHAUST SYSTEM:** Industrial exhaust silencer system / SCR DOC (US) / SCR DPF (EU) Aftertreatment system.
- ENGINE SHUTDOWN:** Automatic engine shutdown protection equipment with LED indicator for low oil pressure, high engine temperature, low coolant level, overspeed, and fail to start.
- ENGINE AUTO-START:** Set mounted autostart control and instrument cubicle containing voltmeter with phase selection switch, ammeter with phase selection switch. dual scale frequency/ tachometer, water temperature gauge, oil pressure gauge, battery, voltmeter, hours run counter, 3 attempt starting timer, mode selector switch run/off/auto, emergency stop button, lamp test/reset button, terminals for remote start, remote emergency stop and common alarm signal.
- CIRCUIT BOARD:** Set mounted circuit breaker cubicle containing suitably rated 3 pole moulded case circuit breaker. Instruction manuals and electrical wiring diagrams

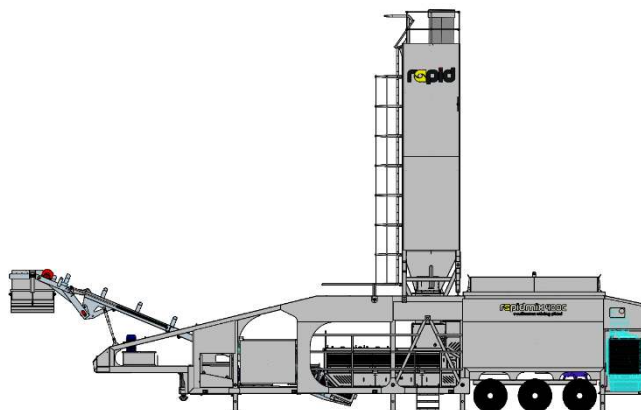

PLANT CONTROL SYSTEM:

The system uses an Allen Bradley Micrologix Processor to control all of the plant functions for automatic control with manual control backup via the touchscreen.

CONTROL PANEL: The operator control panel has push buttons and selectors to activate the genset and compressor etc. All automatic and manual control is provided by the HMI on the panel.

AUTOMATIC CONTROL: A 15" touch screen HMI operator interface is used for operator inputs and display of all parameters. This interfaces with the processor to control the plant. A backup laptop PC is provided to enable the plant to be operated remotely (via WiFi connection).

SOFTWARE FEATURES: Storage of up to 50 Recipes: each recipe contains the details of a specific mix, which is the ratio of cementitious product to aggregate. Stock Control: cement stock and usage are stored in memory and may be displayed or printed out. Printer: the printer will record batches produced and a print will be given after each batch with details of material produced. Plant Alarms: an alarm message will be displayed on the HMI and a print-out given of the alarm fault together with date and time. (an audible and visual alarm is available where operator may be away from the panel and is still made aware of it.)

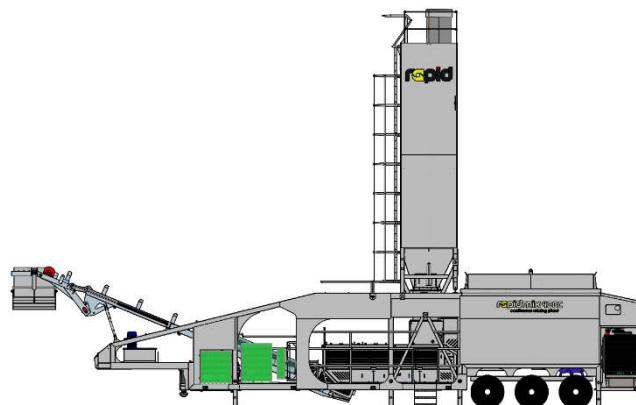

REMOTE ACCESS:

A WiFi system is fitted allowing the control system to communicate locally to the backup pc etc. Also fitted is the facility to allow remote access via the 3G mobile phone network, allowing client’s management to get production reports etc and for our technical staff to assist with fault finding and download software updates. A 3G service for the suitable phone network should be provided by the client.

STARTER PANELS:

The starter panels, house the starters for all of the drive motors on the plant and variable speed drives for the drives that adjust in operation.

MIXER AMP DISPLAY (ON HMI SCREEN)

To display the mixer amps on the HMI screen. When a high level setpoint is reached, the PIL system will alarm only, when an extreme high level setpoint is reached, the PIL system will stop material feeding into the mixer immediately

SPRING RETURN SELECTOR:

Manual 3 Pos Spring Return Selector – For Gob Hopper & Plant Hold Selector. Supply a 3-position selector, spring to centre to the face on the control panel with the following function:
 Left – Manually Close, Centre – Automatic Operation, Right – Manually Open
 Supply a 2-position fixed selector for Plant Hold

After the HMI powers up, the home screen (the running screen) is displayed. This screen is where the operator will gain the majority of the information when the plant is running.

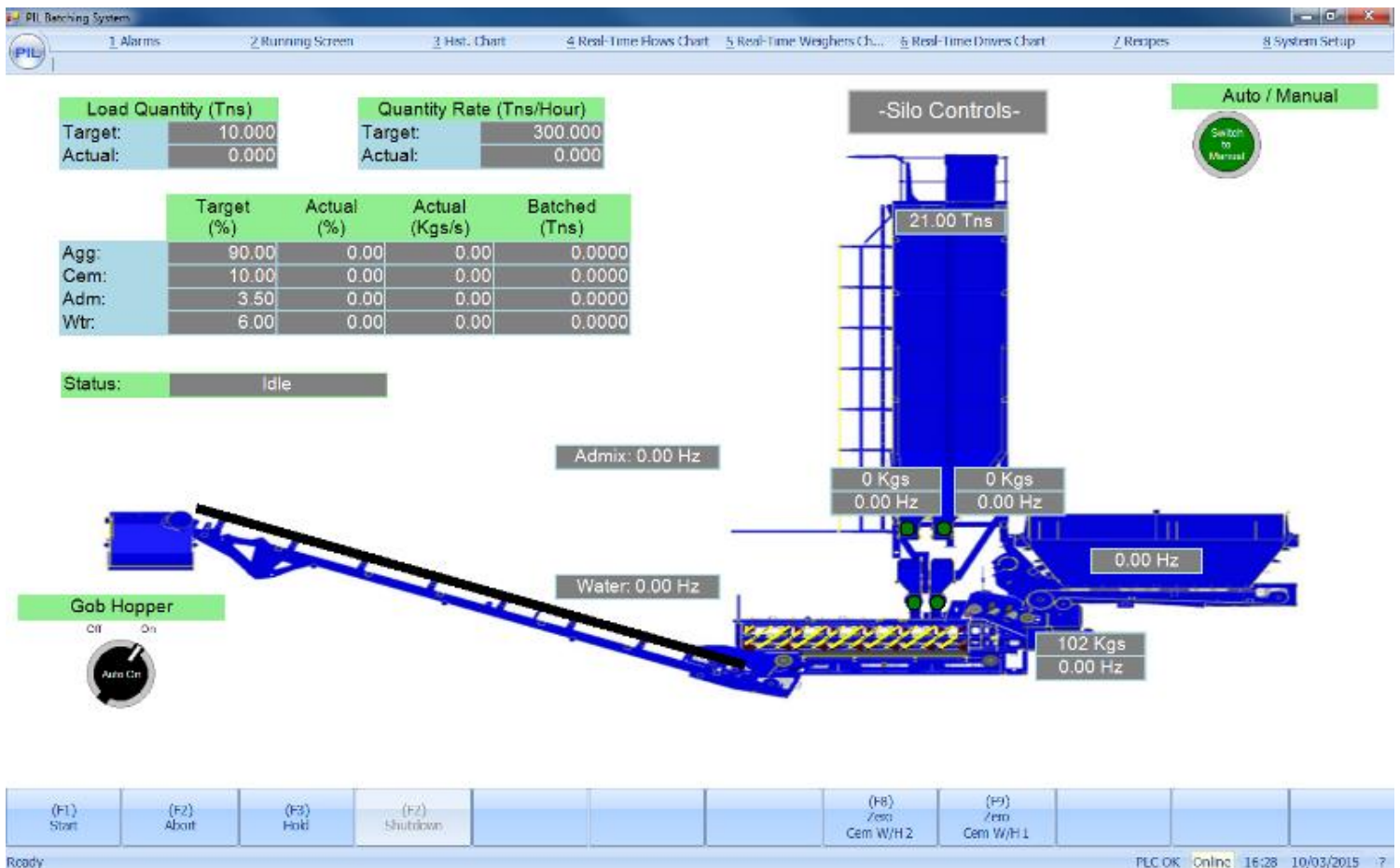

RAPIDMIX OPTIONS

OPTION 1 ADMIX SYSTEM

Litre counter and additive pump to measure the flow rate of additive into the mixer.

The Admixture Metering Systems are compact self-contained units that can accurately and very reliably dispense any amount of admixture.

The admixture metering system is based on microprocessor technology utilizing an electrical pulse from the flow of admixture through a flowmeter.

Outputs Available:

- 12 LPM - transmitter options 33.3 or 100 PPL
- 50 LPM - transmitter options 10 PPL or 4 PPL

Electrical Specification:

- 12 LPM - Pump230/1/50Hz 0.18 Kw IP55 1.4 amps 1430 rpm
- 50 LPM - Pump230/1/50Hz 0.75 Kw IP55 4.4 amps 2790 rpm

Reed Switch Maximum voltage 110v

<u>SIZE</u>	<u>LENGTH</u>	<u>WIDTH</u>	<u>HEIGHT</u>
12 LPM (Litres per Minute)	120cm	30cm	45cm
50 LPM (Litres per Minute)	130cm	30cm	45cm

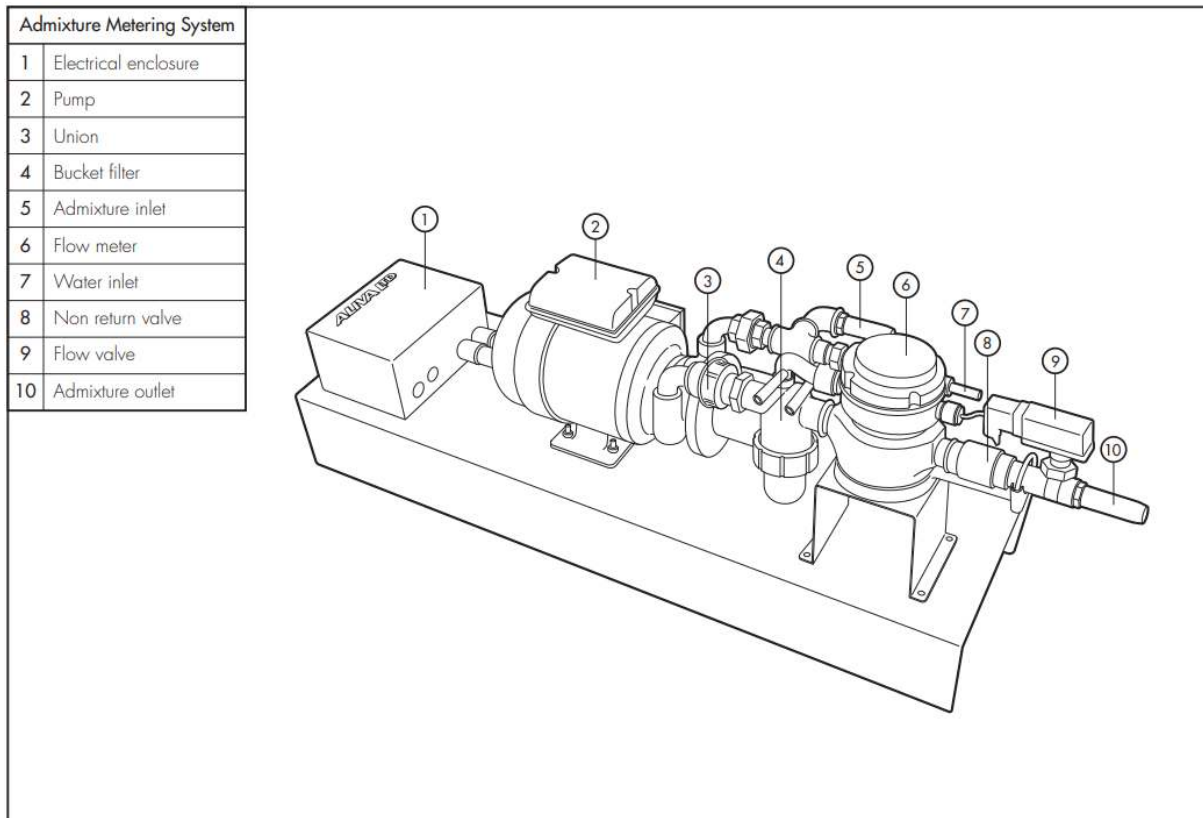

OPTION 1a MULTIPLE ADMIX SYSTEMS

Pneutrol can provide up to 4 x outputs in the PLC to control each of the 4 admixes – a separate output for each admix.

The user will define each admix material within the software, if the admix is used in the recipe, the output for that admix will be energised during the mixing process as would be normal, Pneutrol will then count and record the pulses from each admix and this will be stored in the production file for the loads being mixed. As each load is being mixed, the actual admix value used will be shown on screen – it is totally up to the operator to ensure this is set correctly to achieve the flow required. If the admix is not in line with the desired flow rate, Pneutrol are not to alarm, nor stop the machine.

All control of the admix, speed control, verification the admix is running, pumps, pulsers etc. to be supplied and installed by others.

Pneutrol assume there are enough spare inputs and outputs on the system to accommodate the changes required above. Pneutrol assume all site wiring and installation by others. Uploading of new programme to be done remotely via the modem link.

OPTION 2 AGGREGATE BIN OPTIONS
OPTION 2a AGGREGATE BIN DIVISION PLATE REMOVAL

Rapid International can provide the option of having no aggregate bin division plate included with the Rapidmix unit if preferred.



OPTION 2b MOISTURE PROBE(S)

Supply and installation of up to 2No Hydronix Moisture Probes to the aggregate storage bin.

The Hydro Probe II sensor is designed to give the greatest possible flexibility for measuring moisture content within aggregate storage bins and is the first microwave sensor to use digital measuring techniques, providing greater accuracy and range of measurement than any other sensor on the market.



The Hydro Probe II detects rapid changes in moisture content by sampling the material 25 times per second and then providing the Pneutral Control system with a direct analogue signal allowing the water/weight compensation figure to be calculated.

Pneutral Engineers will mount the probe and install all cabling

OPTION 2c VIBRATOR BIN CLEANING SYSTEM

Supply and installation of a Three-phase asynchronous electric Vibrator to the side of the bin to assist with the cleaning of material from within the bin. Up to 2No Vibrators can be supplied and installed to the aggregate storage bin.



OPTION 2d AGGREGATE BIN AGITATOR

Rapid can provide the option to include an Aggregate Agitator to the Aggregate Bin area of the Rapidmix machine. The Agitator assists with breaking down and mixing clumpy/ difficult material together within the Aggregate Bin unit to promote a homogeneous mix before being conveyed to the mixing chamber.

The Aggregate Bin Agitator can be offered in a single or twin configuration.

Each Agitator is powered by a 5.5 kw electric motor and factory-made with serrated impellers attached all along the agitator shaft.

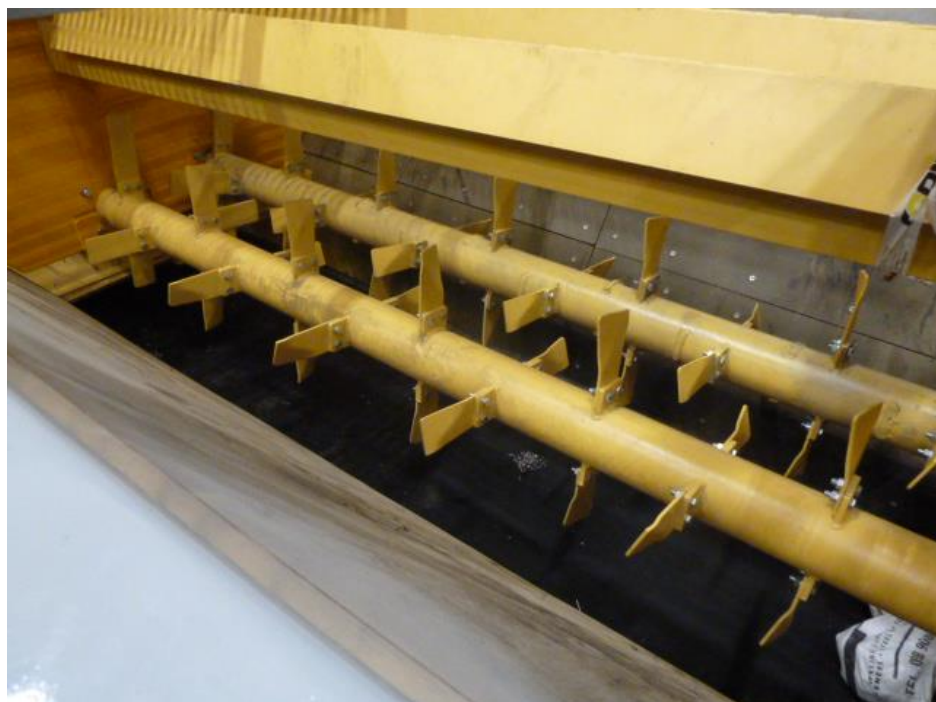

OPTION 3 HOPPER GRID OPTIONS
OPTION 3a STATIC/ VIBRATING / TIPPING GRID FOR HOPPER

Optional Static grid fitted to aggregate bin opening to manage oversized/clumpy materials from entering the hopper

Optional Vibrating grid fitted to aggregate bin opening to manage oversized/clumpy materials from entering the hopper

Optional Tipping grid fitted to aggregate bin opening to manage oversized/clumpy materials from entering the hopper.



OPTION 4 COLD FEED BINS (STATIC OR MOBILE CONFIG.)

2, 3 or 4 bins available in a fully mobile or static unit allowing for additional aggregates to be used.



OPTION 5 AUXILIARY SILO

Option for a standalone auxiliary silo manufactured by Rapid to allow further storage options. The silo can be made mobile.

NB: The Auxiliary Silo is installed with the material added via volumetric feed control.



Auxiliary silo

OPTION 5a AUXILIARY SILO 'HARDWARE READY'

Rapid can prepare the Rapidmix plant to be 'Auxiliary Silo' ready by having the plant's hardware setup in preparation for any future decision made by the user to add an Auxiliary Silo.

Option to have the Rapidmix 'hardware ready' for any future decision to connect an Auxiliary Silo, via built in Power & Communications outlets to connect the Auxiliary Silo from the Rapidmix.

OPTION 6 POWER CHANGE-OVER OPTION

Rapid offers the opportunity to operate the Rapidmix with 'Power Change-over' capabilities. The Power Change-over option allows the user to switch the power source to the plant from either the onboard Genset or by plug-in direct mains power supply.



The Rapidmix can be fitted with Power Change-over capabilities via the installation of a Changeover Switch. The Changeover Switch is supplied and installed by Rapid. Pneutrol will install cabling to and from Changeover switch to leave the Rapidmix, Power Change-over ready.

Rapidmix – Main/Generator Manual Changeover Panel features:

2 x 630Amp 4 Pole MCCB's for mains/generator incoming supplies.

1 x 630Amp 4 Pole manual Changeover Switch C/W handle kit and terminal covers.

All inside a 1000x700x250mm Deep Enclosure

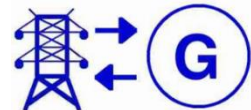

OPTION 7 ELECTRICAL ADD-ONS OPTION 7a LONGER CABLES FOR MOVING CONTROL PANEL

To modify the Rapidmix machine to incorporate plugs and sockets into the electrical cabling at the control panel, with the following cable lengths available:

- 10m (32ft) cable run
- 20m (65ft) cable run
- 30m (98ft) cable run

OPTION 7b DOMESTIC DOUBLE SOCKETS

Rapid can deliver the option to have domestic appliance graded Double Sockets mounted within the panel to enable the customer to plug in appliances.

Rapid provide a 1kVA Transformer with circuit protection on primary & secondary of transformer.

Sockets can be fitted to suit the following supply voltages:

USA: Double Socket, Type A & B, 115-120V AC

CANADA: Double Socket, Type A & B, 115-120V AC

AUSTRALIA: Double Socket, Type I, 230V AC

UK: Double Socket, Type G, 230-240V AC

EU: Double Socket, Type C, 220-230V AC

OPTION 7c SOFTWARE UNITS DISPLAY

To ensure effective user interaction with the Controls Panel, Rapid can offer to display all the units and figures that appear on the control panel in either Imperial units (ft or lbs) or Metric units (m or kgs) depending on customer preference.

OPTION 8 BELT SCALE WEIGHER (Applicable to UK, EU & AUS)

To continuously measure and report flow rates and totalized amounts of materials being transported on the Out-loading Conveyor belt. The weight of the material transported is determined by weighing the belt load and measuring the belt speed.

This option is offered as an extra to the following markets: UK, EU & Australasia

****Standard on North America machine variant only****

OPTION 9 CUSTOMISED PAINT COLOUR

The plant can be painted in any colour. Our standard colours (Construction Yellow & Grey) will be applied if no colour is specified, however for branding purposes customer colours can be used.

OPTION 9a ADDITIONAL DECALS

The plant can be customized to include decals of the company brand and business info.