

3 FRACTION STAR SCREEN

SUPERSCREENER 3F SEMI-TRAILER / SIX-WHEEL TRAILER



FINE FIRST, COARSE LATER

The 3F star screen semi-trailer performs at its best when rehabilitating soil, processing biomass and recycling various waste materials such as domestic, garden and commercial waste. The low fuel consumption ensures not only the reduction of costs, which can then be reinvested in other projects, to name an example. By fine before coarse screening, the 3F star screen trailer ensures energy-saving and thus environmentally friendly efficiency.

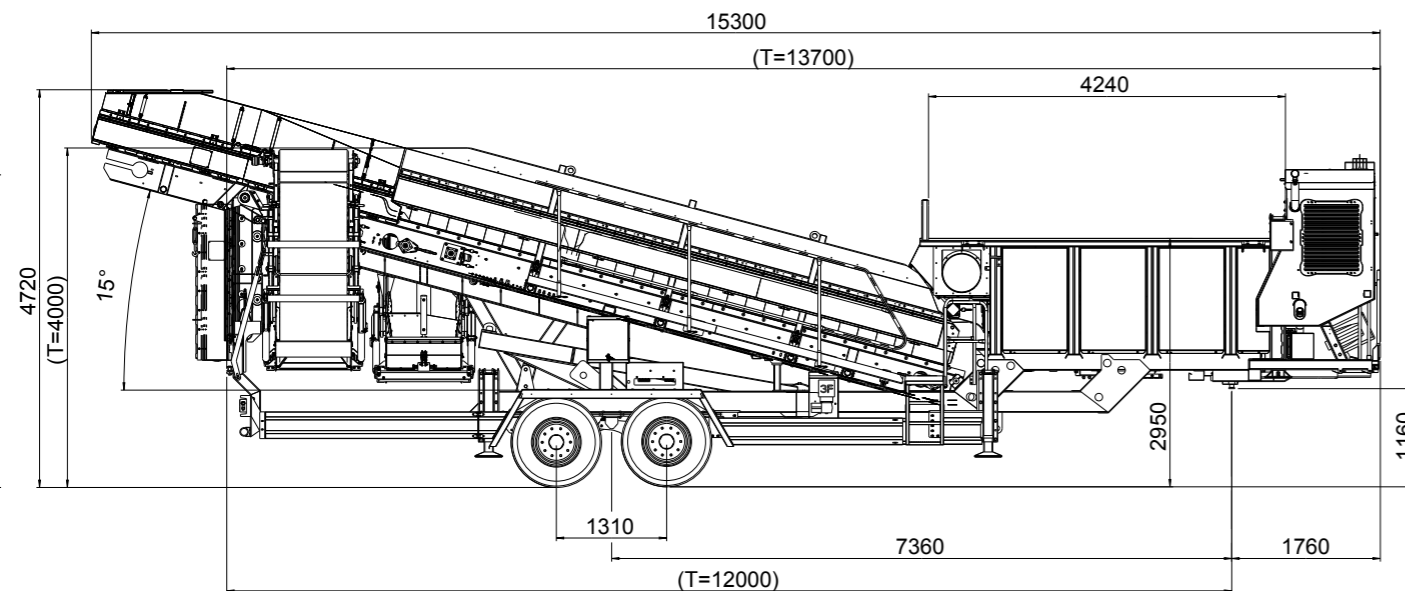
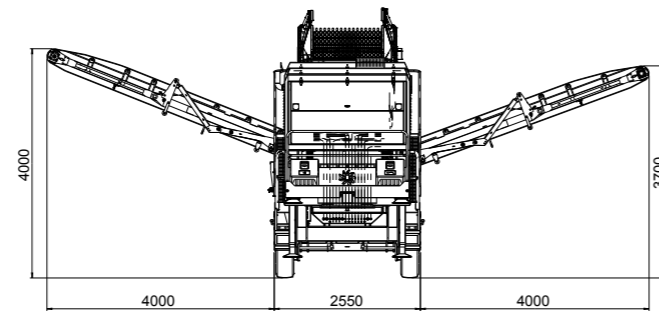

	Semi-trailer / six-wheel-trailer for 80 km/h as per StVO, with ABS	Semi-trailer / six-wheel-trailer for 80 km/h as per StVO, with ABS
Total weight	approx. 19,000 kg	approx. 19,000 kg
Drive	Hybrid	Diesel hydraulic
Output	Power unit 110 kVA Electrical motor 75 kW	Diesel engine 104 kW / 141 PS
Emission standard	In accordance with the latest emission standard	EU Stage V / EPA Tier 4 Final
Cubic capacity	4.5 litres	4.5 litres
Fuel tank	300 litres	300 litres
Hopper volume	up to 7.5 m ³	up to 7.5 m ³
Screen deck	Fine fraction	Middle fraction
Width	1,250 mm	1,250 mm
Length	6,900 mm	3,700 mm
Fractions	10 - 200 mm	28 - 200 mm
Star size	300, 287, 230, 216 or 170 mm	300 mm
Star speed	0 - 230 rpm, infinitely variable	0 - 180 rpm, infinitely variable

