

DRUM SCREEN

NH 6020 XL TRACKED CHASSIS FRAME



THE GIANT OF CRAWLERS

Like its smaller sibling, the NH 6020 H crawler tracks, the XL variant is a flexible powerhouse that excels on rough terrain thanks to its robust tracked chassis frame.

The extra-large single-volume infeed hopper allows for the time-efficient processing of high-volume materials such as bark and waste wood or large quantities of green waste, wood chips and excavated sand/soil.

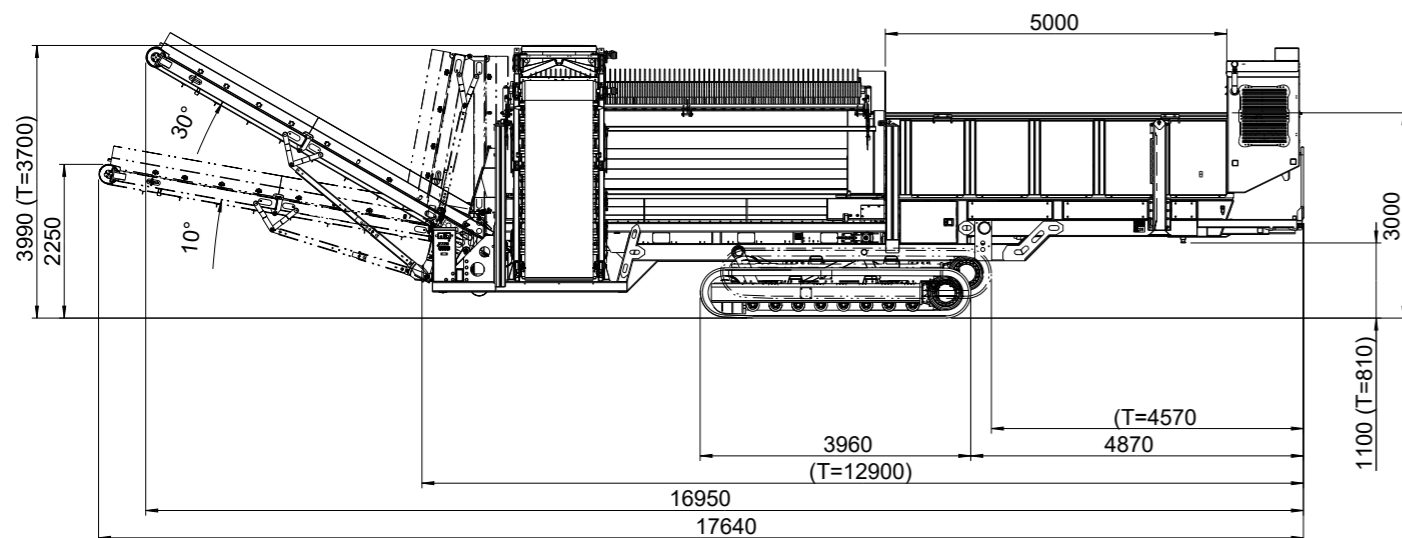
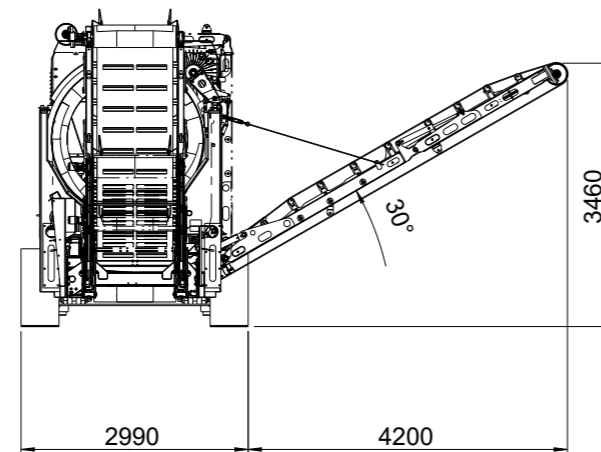

	Self-driving tracked chassis frame; two travel speeds
Total weight	approx. 24,000 kg
Drive	Diesel hydraulic
Diesel engine power	86 kW / 117 PS
Emission standard	EU Stage V / EPA Tier 4 Final
Cubic capacity	4.5 litres
Fuel tank	300 litres
Hopper volume	7 m ³
Drum screen	
Length	5,500 mm
Diameter	2,000 mm
Material thickness	6 - 8 - 10 - 12 mm
Hole width	8 - 100 mm
Drum speed	0 - 21 rpm

