

DRUM SCREEN NH 6020 TRACKED CHASSIS FRAME



ROBUST CHASSIS FRAME

The robust tracked chassis frame with two travel speeds allows the NH 6020 H crawler to assert itself on difficult terrain and maintain its secure footing.

The flexible drum screen is equipped with a diesel hydraulic drive and features energy efficiency combined with high performance.

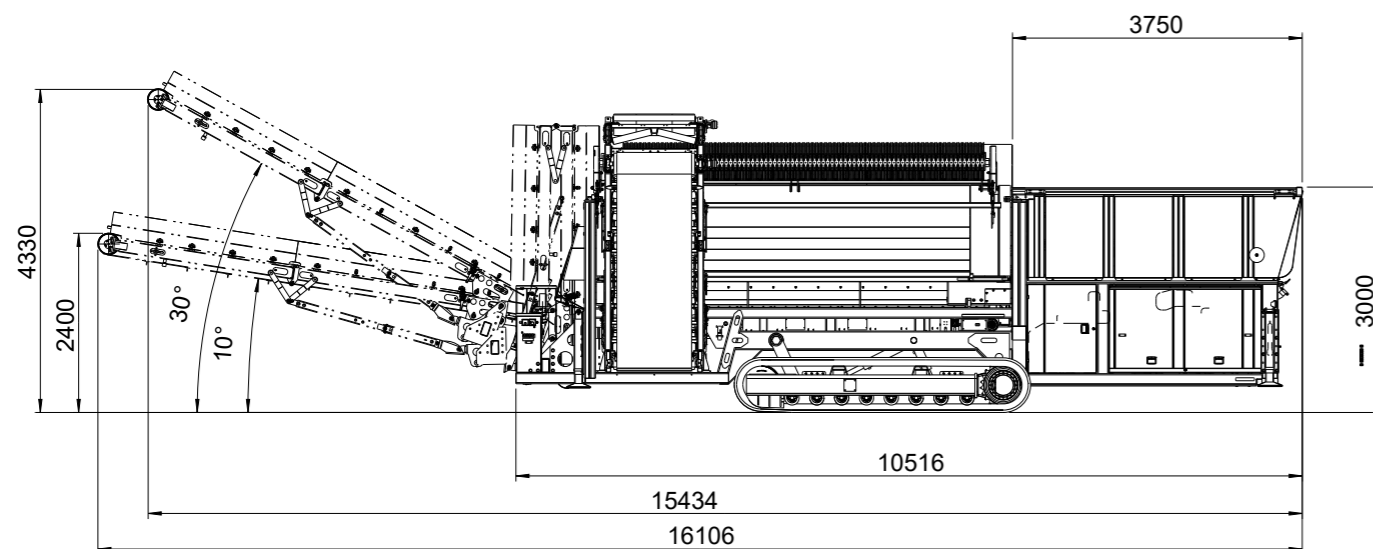
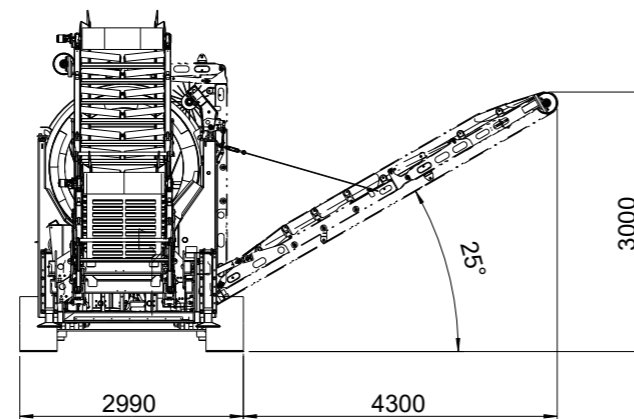

	Self-driving tracked chassis frame; two travel speeds	Self-driving tracked chassis frame; two travel speeds
Total weight	approx. 24,000 kg	approx. 24,000 kg
Drive	Hybrid	Diesel hydraulic
Output	Power unit 110 kVA Electrical motor 55 kW	Diesel engine 86 kW / 117 PS
Emission standard	In accordance with the latest emission standard	EU Stage V / EPA Tier 4 Final
Cubic capacity	4.5 litres	4.5 litres
Fuel tank	300 litres	300 litres
Hopper volume	5 m ³	5 m ³
Drum screen		
Length	5,500 mm	5,500 mm
Diameter	2,000 mm	2,000 mm
Material thickness	6 - 8 - 10 - 12 mm	6 - 8 - 10 - 12 mm
Hole width	8 - 100 mm	8 - 100 mm
Drum speed	0 - 21 rpm	0 - 21 rpm

