

SINGLE-SHAFT-SHREDDER

TARGO 2500 TRACKED



A MATCH FOR ANY TERRAIN

TARGO 2500 Track is made for moving on rough ground such as landfills and construction sites. Thanks to the remote control, setup of the system at the work site is quick and easy. The two speed track undercarriage gives you both speed, strength and precision when moving the shredder.

Optionally, the track pads can be replaced, e.g. by flat shoes or equipped with rubber pads, to protect sensitive surfaces such as asphalt.

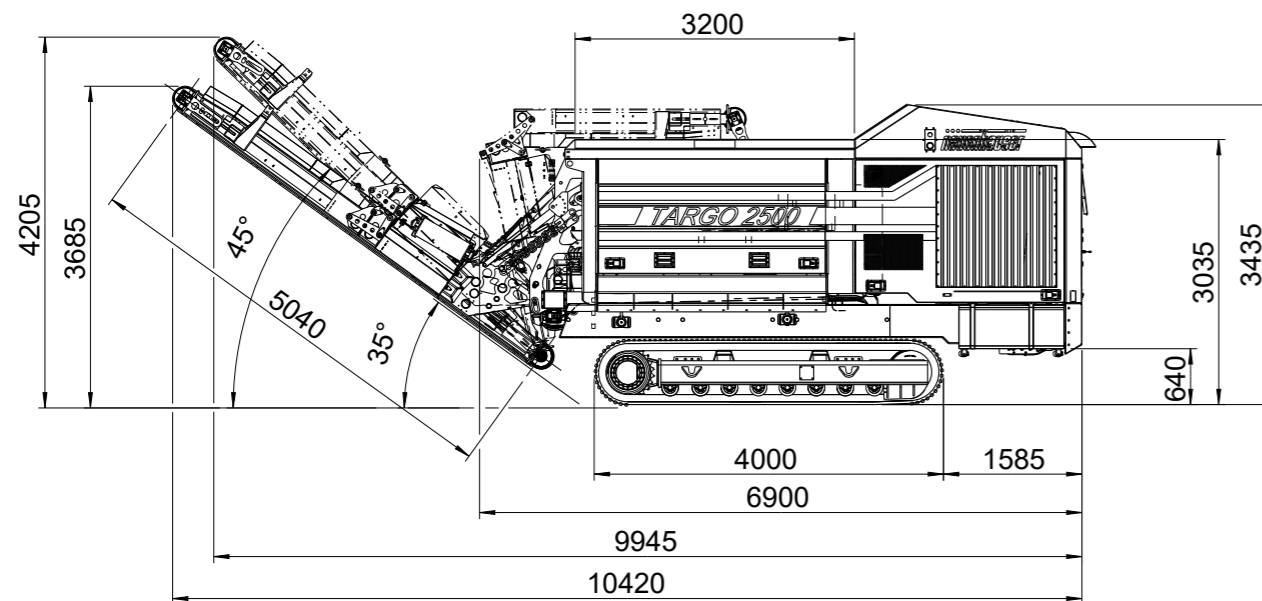
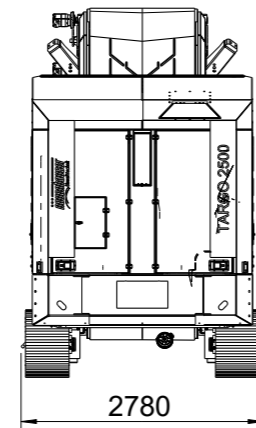

Self-driving tracked chassis frame;
with two variable driving speeds

Total weight	approx. 28,000 kg	
Drive		
Engine type	Diesel direct drive, Volvo Penta TAD 1182 VE	
Power	285 kW at 1800 rpm	
Exhaust emission standard	In accordance with the latest emission standard	
Engine displacement	11 litre	
Fuel tank	approx. 500 litre	
Shaft		
Length	2,500 mm	
Diameter	600 mm	
Rotation speed	max. 28 rpm	
Qty. of teeth	16 (optionally 32 teeth)	
Comb		
Length	2,500 mm	
Qty. of teeth	16	
	Discharge conveyor belt	Collecting conveyor belt
Belt width	1,200 mm	1,000 mm
Length	5,040 mm (optionally 7,500 mm)	3,335 mm

