

DRUM SCREEN NH 6020 SEMI-TRAILER



ALWAYS WELL DISPOSED

As an alternative to the NH 6020 H trailer model, Neuenhauser Umwelttechnik also offers the compact trailer model NH 6020 H. The performance, efficiency and ease of maintenance remain high, saving time and money.

The high-quality drum-screen machine is ideal for applications such as biomass processing, wood recycling and soil rehabilitation.

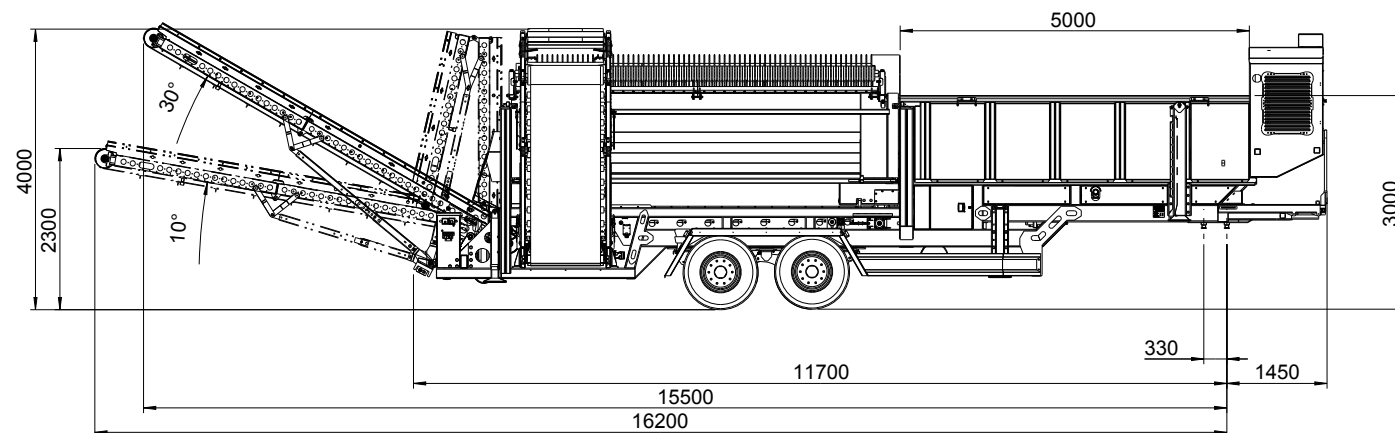
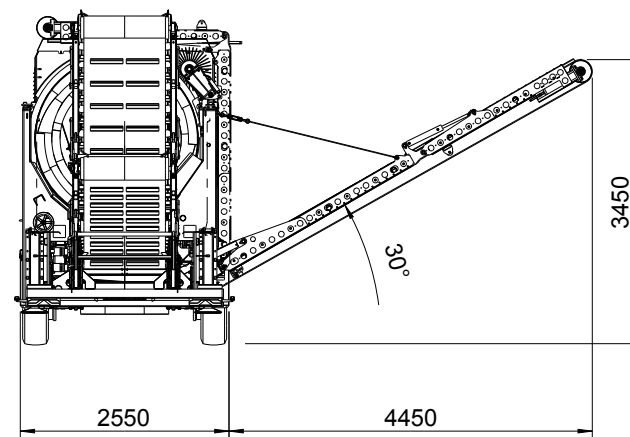

Semi-trailer with brake system and vehicle lighting for 80 km/h as per StVO, with ABS	
Total weight	approx. 18,000 kg
Drive	Diesel hydraulic
Diesel engine power	86 kW / 117 PS
Emission standard	EU Stage V / EPA Tier 4 Final
Cubic capacity	4.5 litres
Fuel tank	300 litres
Hopper volume	7 m ³
Drum screen	
Length	5,500 mm
Diameter	2,000 mm
Material thickness	6 - 8 - 10 - 12 mm
Hole width	8 - 100 mm
Drum speed	0 - 21 rpm

