

SINGLE-SHAFT-SHREDDER

TARGO 2500 TRAILER



MOBILE AND INDEPENDENT

Efficient, reliable and flexible, the TARGO 2500 single-shaft shredder is the perfect all-round and energy efficient shredder. The TARGO 2500 trailer version is the best solution for maximum flexibility and shredding of material at various job sites.

The robust spring suspended kingpin chassis is road legal for registration up to 80 km/h – for your quick and easy transport between job sites.

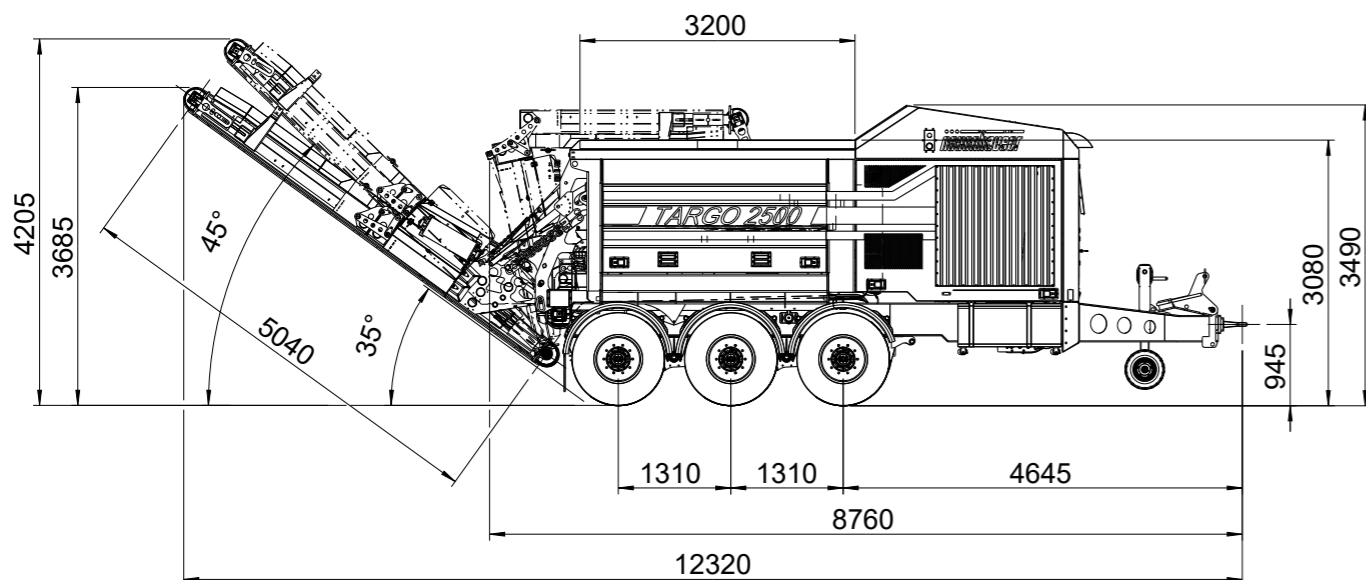
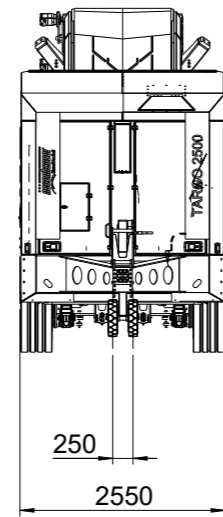

3-axle spring chassis with ABS brake system and vehicle lighting for 80 km/h as per StVO, with ABS

Total weight	approx. 25,000 kg	
Drive		
Engine type	Diesel direct drive, Volvo Penta TAD 1182 VE	
Power	285 kW at 1800 rpm	
Exhaust emission standard	In accordance with the latest emission standard	
Engine displacement	11 litre	
Fuel tank	approx. 500 litre	
Shaft		
Length	2,500 mm	
Diameter	600 mm	
Rotation speed	max. 28 rpm	
Qty. of teeth	16 (optionally 32 teeth)	
Comb		
Length	2,500 mm	
Qty. of teeth	16	
	Discharge conveyor belt	Collecting conveyor belt
Belt width	1,200 mm	1,000 mm
Length	5,040 mm	3,335 mm

